

**NEW...**

**WMMP**



# Wall Mount Mini Packaged System

## Innovative/Fresh Replacement to Plain PTAC/PTHP

### Stylish/Comtemporary, Your Hotel/Room Look Different from Others

- \* 2 Holes & 1 Wall Mount, The Only One on the Rock
- \* 2 Men & 1 Hour Installation, A Piece of Cake

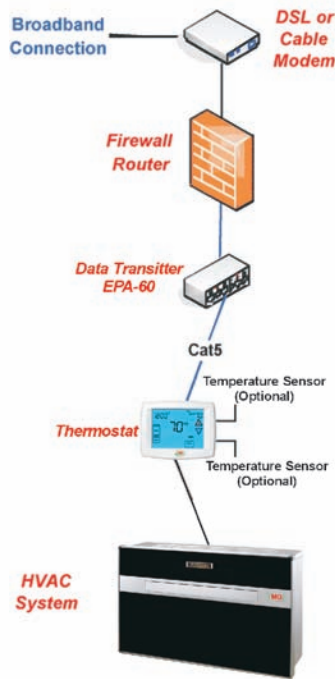

Optional Net-work Control System

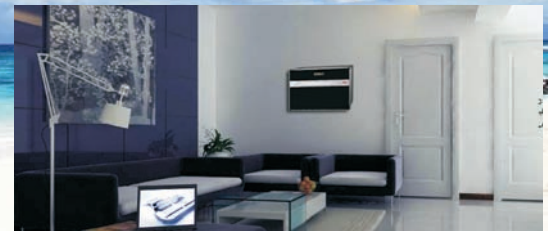

**YMGI, A Comfort Maker, A Joy Companion, A Satisfaction Guarantor...**

### APPLICATION EXAMPLES:

- |                      |                 |                |
|----------------------|-----------------|----------------|
| * HIGH-RISE BUILDING | * CONDOS        | * APARTMENTS   |
| * HOTELS             | * RESORTS       | * OFFICES      |
| * HOMES              | * FACTORIES     | * RESTAURANTS  |
| * SUNROOMS           | * NURSING ROOMS | * MOBILE HOMES |

### FEATURES:

- |                                      |                                    |                           |
|--------------------------------------|------------------------------------|---------------------------|
| * 2-HOLE & 1 WALL MOUNT: ROCK & ROLL | * CONDENSATE-NATURAL AND PUMP-LIFT | * OPTIMIZED SYSTEM DESIGN |
| * SELF-CONTAINED                     | * 24-HOUR TIMER                    | * WORLD-CLASS COMPRESSOR  |
| * DIGITAL DISPLAY                    | * MEMORIES                         | * ENHANCED COPPER/COIL    |
| * WIDE SCREEN WITH STYLISH LOOKING   | * SLEEP MODE                       | * SUPER HIGH EFFICIENCY   |
| * SOFT TOUCH AND/OR REMOTE CONTROL   | * PRE-CHARGED SEALED SYSTEM        | * USER-FRIENDLY           |
| * QUICK COOLING AND HEATING          | * OVERCURRENT & THERMAL PROTECTION | * ENVIRONMENT-FRIENDLY    |
| * INDEPENDENT DEHUMIDIFICATION       | * NOISE ABSORPTION MATERIAL        | * VERY EASY INSTALLATION  |
| * ACTIVE / INTELLIGENT DEFROSTING    | * THOROUGHLY TESTED                | * VERY EASY OPERATION     |
| * WASHABLE FILTER                    | * PROVEN RELIABILITIES             | * VERY QUIET OPERATION    |

### SPARE PARTS AND ACCESSORIES:

- |                              |  |                        |
|------------------------------|--|------------------------|
| * HOSE-INTAKE                | * FILTER-STANDARD WASHABLE             | * REMOTE CONTROL       |
| * HOSE-EXHAUST               | * FILTER-HIGH EFFICIENCY               | * PHONE CONTROL        |
| * BIRDPROOF GRILLE           | * MOUNTING BACKET                      | * THERMOSTAT           |
| * CONTROL BOARDS/COMPRESSORS | * 1:1 MOUNTING HOLES DRILLING TEMPLATE | * FRONT PANEL (SCREEN) |

YMGI Group New Energy is the Sole Owner & User of YMGI Brand. Any Infringement Is to Be Prohibited and Prosecuted. Reporting or Assisting to Stop Any Infringement is to Be Rewarded. YMGI is the Trademark and Property of YMGI Group New Energy. Copyright of YMGI Group New Energy.

Proudly Designed and Manufactured and Distributed and Marketed by YMGI Group (New Energy). No Other Persons or Companies in the World, Including China, USA and Canada, Are Authorized to Use YMGI Brand. Reporting or Assisting to Stop Any Infringement is to Be Rewarded.



- OPTIONS AT MANUFACTURE:**
- \* Front Panel of Different Style / Color
  - \* LCDI Cord
  - \* Standard Thermostat Control

MODEL NO.			WMMS-09K-31A(P4)	WMMS-12K-31A(P4)	WMMS-09K-32A(P4)	WMMS-12K-32A(P4)	WMMS-09K-34A(P4)	WMMS-12K-34A(P4)	WMMS-09K-34B(P4)	WMMS-12K-34B(P4)
THERMAL MODE			AC ONLY		Heat Pump		Heat Pump + Aux. Heater		HP + Back-Up Heater	
COOLING CAPACITY	Rated ID 80/67F OD 95F	BTU/H (1), 2)	9000	12000	9000	12000	9000	12000	9000	12000
HEATING CAPACITY	Rated ID 70/60F OD 47F (17F)	BTU/H (1), 2)	N/A	N/A	9500(5000)	12800(6800)	9500(5000)	12800(6800)	9500(5000)	12800(6800)
ELECTRIC HEATER	RATED	WATTS	N/A	N/A	N/A	N/A	1500-1800	1500-1800	2400-3000	2400-3000
DEHUMIDIFICATION	RATED	PTS./DAY	42.2	48.6	42.2	48.6	42.2	48.6	42.2	48.6
SEER	RATED	BTU/H.W	13	13	13	13	13	13	13	13
HSPF	RATED	BTU/H.W	N/A	N/A	8.1	8.0	8.1	8.0	8.1	8.0
SOUND LEVEL (POWER)	INDOOR/OUTDOOR	dB(a)	22-23/36-38	22-23/36-38	22-23/36-38	22-23/36-38	22-23/36-38	22-23/36-38	22-23/36-38	22-23/36-38
REFRIGERANT	PRE-CHARGED	YES	R410A	R410A	R410A	R410A	R410A	R410A	R410A	R410A
INPUT POWER SOURCE			A: 115/1/60 F: 220/1/50						B: 208-230/1/60 F: 220/1/50	
POWER CONSUMPTION	COOLING	WATTS	960	1130	960	1130	960	1130	960	1130
	HEATING	WATTS	N/A	N/A	920	1095	920	1095	920	1095
TOTAL CURRENT	COOLING	AMP	8.9	9.8	8.9	9.8	8.9	9.8	4.5	4.9
	HEATING	AMP	N/A	N/A	8.0	9.5	8.0+5.0	9.5+5.0	4+10.4	4.7+13.0
MCA	FOR WIRE SIZING	AMP	15	18	15	18	20	20	20	20
MINIMUM WIRING SIZE	LENGTH OF LESS THAN 15 FT	AWG	14				12			
HVAC CIRCUIT BREAKER	FOR FUSE SIZING	AMP	20	30	20	30	30	30	30	30
INDOOR FAN MOTOR	FAN	TYPE	CROSS-FLOW							
		CFM	230/265/300	230/265/300	230/265/300	230/265/300	230/265/300	230/265/300	230/265/300	230/265/300
	MOTOR	RATED WATTS	14-15	14-15	14-15	14-15	14-15	14-15	14-15	14-15
MAX. SPEED		1350	1350	1350	1350	1350	1350	1350	1350	
OUTDOOR FAN MOTOR	FAN	TYPE	CENTRIFUGAL							
		CFM	1175	1175	1175	1175	1175	1175	1175	1175
	MOTOR	STYLE	PSC							
COMPRESSOR	HERMETIC	BRAND	TOSHIBA OR PANASONIC OR HITACHI OR EQUIVALENT							
CONTROL	THERMOSTAT CONTROL	REPLACING PCB	OPTIONAL	OPTIONAL	OPTIONAL	OPTIONAL	OPTIONAL	OPTIONAL	OPTIONAL	OPTIONAL
	REMOTE CONTROL	INCLUDED	Yes	Yes	Yes	Yes	Yes	Yes	Yes	Yes
	LOW AMBIENT CONTROL	INCLUDED	Yes	Yes	Yes	Yes	Yes	Yes	Yes	Yes
	DEFROST ON DEMAND	INCLUDED	Yes	Yes	Yes	Yes	Yes	Yes	Yes	Yes
CONNECTIONS	ANTI-ICE	INCLUDED	ID/OD	ID/OD	ID/OD	ID/OD	ID/OD	ID/OD	ID/OD	ID/OD
	DRAINAGE	DRAIN PIPE	1/2"ID 3/4"OD							
	WIRES	OPEN STRIPPED END	3 Ft.	3 Ft.	3 Ft.	3 Ft.	3 Ft.	3 Ft.	3 Ft.	3 Ft.
LCD I		OPTIONAL	OPTIONAL	OPTIONAL	OPTIONAL	OPTIONAL	OPTIONAL	OPTIONAL	OPTIONAL	
AIR PIPES-ROUND INTAKE / EXHAUST	DIA./MAX. FT.	8 INCHES / 25 Ft.								
LOUVER-INTAKE / EXHAUST	TYPES	STANDARD-ROUND PIPE / EXTERIOR. OPTIONAL-ROUND PIPE-RECTANGULAR EXTERIOR								
INSTALLATION	LIMIT-HIGH (TOP TO GROUND)	FT	8	8	8	8	8	8	8	8
	LIMIT-LOW (TOP TO GROUND)	FT	0	0	0	0	0	0	0	0
INSTALLATION KIT	AIR-FLOW PIPES	INTAKE / EXHAUST	1/1							
	GRILLES	INTAKE / EXHAUST	1/1							
WORKING AMBIENT TEMPERATION RANGES (AC / HP)	F	45-104 / NA		45 to 104 / 35 to 80		45 to 104 / 35 to 80		45 to 104 / 35 to 80		
WEIGHT	NET	LBs	104	106	104	106	104	106	104	106
	GROSS	LBs	112	118	112	118	112	118	112	118
DIMENSION WxHxD	UNIT	INCH	37 x 24 x 10							
	BOX	INCH	39 x 26 x 12							
LOADING CAPACITY	20/40/40/HQ	SETS	130/260/312							

**NOTES:**

- 1) Electric data above is based upon 60HZ. For data of 50 HZ, look up in the nameplate on the unit.
- 2) Performance rated for matched system at standard conditions-cooling ID 80/67F, OD 95F, heating ID 70/60F, OD 47/43F. Unit performance varies when weather changes from the standard one.
- 3) Select equipment capacity sizes per space load calculation schedule and cooling & heating hours. Not to over size or under size equipment.
- 4) Watch unit operation during extreme weather conditions in summer and winter. After the unit is used for quite a while in these wheather, unit may step into protection mode and stay idle.

**YMG Group, POB 1559**  
**YMG Group New Energy, POB 1668**  
 O'Fallon, MO 63366, USA  
 Tel:(866)833-3138 Fax:(866)377-3355  
 Web Site: www.ymgigroup.com  
 Email: info@ymgigroup.com

**Rep. Or Distributor:**