



YMGI, Engineered Comfort Products for A Sustainable and Efficient Green World !

INSTALLATION, OPERATION & MAINTENANCE Wall Mounted Mini-Packaged System

09,12K Btu/h

AC or HeatPump (with or without Ele. Heater)



WMMS-09K-31A(PX)	WMMS-09K-31B(PX)
WMMS-09K-32A(PX)	WMMS-09K-34B(PX)
WMMS-12K-31A(PX)	WMMS-12K-31B(PX)
WMMS-12K-32A(PX)	WMMS-12K-34B(PX)
WMMS-09K-31A(P4)	WMMS-09K-31B(P4)
WMMS-09K-32A(P4)	WMMS-09K-34B(P4)
WMMS-12K-31A(P4)	WMMS-12K-31B(P4)
WMMS-12K-32A(P4)	WMMS-12K-34B(P4)



YMGI Group, POB 1559
YMGI Group New Energy, POB 1668
 O'Fallon, MO 63366, USA
 Tel:(866)833-3138 Fax:(866)377-3355
 Web Site: www.ymgigroup.com
 Email: info@ymgigroup.com

Literature Part No: Lit-WMMP-0104-20130917

Subject to Continuous Engineering Change and Product Improvement without Notice.

⚠ WARNING

This product is designed and manufactured free from defects in material and workmanship for the normal use and maintenance. Installation, operation, maintenance and service shall follow professional practices for regular cooling and heating equipment, NEC, State, City or Local Codes and related manuals from YMGI. Otherwise, damage to equipment or property even injury to people may occur.

Installer: Currently licensed HVAC technician only. Read manual before installation. Fully fill in warranty registration card.

User: Keep this manual for future maintenance and service use.

Service: Use this manual for service reference.



Literature Part No: Lit-WMMP-0104-20130917

CONTENTS

MUST READ-ATTENTIONS AND WARNINGS	2
CUSTOMER AND TECHNICIAN MUST READ	2
LIMITED PRODUCT WARRANTY POLICIES	2
LIMITED PRODUCT WARRANTY REGISTRATION CARD	2
CUSTOMER AND TECHNICIAN MUST READ	2
IMPORTANT NOTES	2
A PIECE-OF-CAKE WMMS(P)-Quality of Features	2
A PIECE-OF-CAKE WMMS(P)-Performance Curves (For Reference)	2
A PIECE-OF-CAKE WMMS(P)-Brief Specifications	2
ADVANTAGES OVER TRADITIONAL SYSTEMS	2
UNIT INSTALLATION	2
OPERATION	2
DIAGNOSIS CODE & TROUBLE-SHOOTING GUIDELINE	2
WARRANTY AND TECH. SUPPORT	2
USER NOTES AND SERVICE LOG	2
MEMO	2

CAUTION All Units Shall Be Installed by Experienced or Licensed Contractor Or Technician. Read Manuals before Installation.

CAUTION Following NEC, State and Local Codes and Installation Instructions of All Units, Otherwise Unit Warranty Will Be Void and Serious Damage To People Or Property May Be Caused.

WARNING YMGI Group Shall NOT Take Any Responsibilities for Any Damage or Loss Due to Do-It-Yourself(DIY) self-installation and other Improper Installation or Operation or Natural Disaster.

WARNING Don't Supply Power until All Wiring and Tubing and Checking is Completed. Ground the Unit Following Instructions and NEC, State and Local Codes.

DANGER Connect All Wiring Securely. Loose Wire or Other Bad Contact May Cause Arc or Overheating and Fire Hazard.

End User Technician Contact of Technical Support-Manufacturer

Toll Free Number: 1-866-833-3138 x 703

Email: techsp@ymgigroup.com

(End user needs to contact installation or service technician to check the unit, before the technicians contact manufacturer technical support-straight technical communication)



MUST READ-ATTENTIONS AND WARNINGS

ATTENTIONS

1. Be sure to hire only one certified, licensed HVAC Company to complete 100% of the installation so that all details of the installation are clear, complete and well taken care of.
2. Be sure to have ONLY the licensed HVAC professional perform all parts of the installation. Factory Warranty will be lost if any portion the installation is not performed by licensed HVAC contractor. DIY or partial DIY will void ALL factory warranties. One example of partial DIY would be calling the HVAC technician to release refrigerant or the sort while other installation has or is to be conducted by non-HVAC technician.
3. With hiring a technician that is offering their services as a "side job" and not through their licensed HVAC company may pose a possible risk of an incomplete or unsatisfactory installation of no guaranteed workmanship and lack of further service, if needed.
4. Have the installing technician read in full the installation manual of the product model you have. Some details may vary and some may be the key to determine the success and quality of the installation. Experience with certain manufacturer may not be applied fully to another manufacturer. For example, wiring, refrigerant adjustment and trial testing procedures may differ from manufacturer to manufacturer and model to model. Any ignoring or negligence may cause unit failure or damage which could be irrevocable and permanent.
5. All of YMGI's products are fully tested and have passed rigorous safety and performance standards and others related to the industry, before being packed and shipped. YMGI only uses famous brands as suppliers for their parts that are also known for their high quality and performance. The quality of the installation plays a key role as much as up to 90% importance in your unit's overall performance and lifetime. A poor installation can result in unit failure and inefficiency either immediately or over a period of time.
6. YMGI cannot control every application that our unit's are installed in. It is key that each variable is taken into account in each installation depending your application.

WARNING

The following points below will cause damage to the unit and key components'. This will cause the end user to lose their factory warranty. Below are details that may be missed at the time installation but will eventually over time cause unit failure:

1. Any foreign substances introduced into the system as a result of failure to seal the ends of the refrigeration piping before pulling through structures at time of installation.
2. Not installing an oil P-trap in the suction copper line where indoor unit is located 18' or more below the outdoor unit.
3. Cross piping and/or cross wiring on any units including more than one single zone or a multi zone system.
4. Not conducting a positive leak check by charging the system with dry-nitrogen and soap bubble testing.
5. Not conducting a negative leak check by evacuating the copper lines for 30 minutes and waiting about five minutes. Vacuum must be held for this period of time at 500 micron or better.
6. Not conducting a positive leak check prior to the negative leak check.
7. Not selecting the correct size wire or circuit breaker.
8. Any kinks or improper bending of the copper piping.
9. Any improper flaring or not centering of the flare with the nut, or not tightening the connections.
10. Not trial testing each indoor unit individually.
11. Not reading the provided technical data (temp/time/pressure/current) after the system has been running for a period longer than 10 minutes. Reading this data before this time can provide false readings and provide a false sense of security.
12. Not completing ALL questions on the technician's checklist inside the warranty registration form that is provided with the manuals.

In effort to protect our customers from any possible faulty installation which can lead to premature unit failure, we like to provide this information to you in addition to the technician. You can the judge by yourself and observe while your system is being installed, though your observation may not be treated as any guarantee or witness whether your system would be installed properly and professionally. If at any time you feel that there may be an installation issue, please have your technician contact YMGI at (866)833-3138 x 703 to clear some questions.



CUSTOMER AND TECHNICIAN MUST READ

Dear Customer(s)/End User(s)/Unit Purchaser(s)/Installer(s)/Contractor(s)

Thanks for choosing YMGI products.

The YMGI equipment you purchased is either a split-type or a self-contained cooling/heating system which requires an installer's license, certification, knowledge, experience, carefulness and details for a successful and good installation. This equipment is different from those window or portable air conditioners you can normally purchase from local retail stores such as Home Depot, Lowe's, Sears, etc. which the manufacturer may not require licensed personnel to install.

Reading and following the YMGI Group recommendations, suggestions, and requirements, written in the following pages and other documents, is the first step in our hope and effort to help ensure a smooth installation & proper operation of your products for many years.

WHY DOES YMGI GROUP REQUIRE INSTALLATION AND SERVICE TO BE PERFORMED BY LICENSED OR CERTIFIED HVAC TECHNICIAN/ CONTRACTOR?

1) They have the training and experience to accurately and safely install and service your equipment.

The equipment runs with high-pressure refrigerant and oil and line-voltage. The copper lines must be installed properly to prevent leakage and foreign substances from contaminating the refrigerant system.

2) You will save money in the long run.

If any problems occur on the unit that is fully installed by the licensed or certified contractor, they have the training and experience to correct the problem more efficiently. A technician(s) may be unwilling to repair an issue on a unit that they did not install. If you do find a technician willing to perform the service, there is an increased possibility of higher service fees than normal, increased service visits, or delayed service from that technician.

3) It's the law!

The federal, state and/or local government and authorities have various governing laws or regulations, guidelines, ordinances, etc., requiring only licensed or certified professionals can install and service high pressure HVAC equipment.

SUGGESTIONS, TO AID YOU IN HIRING AN HVAC CONTRACTOR:

- 1) Hire a currently, practicing, licensed/ certified HVAC technician/ contractor. Technicians, who are no longer practicing (retired, etc.) in this field, may not have the updated knowledge or may lack experience on the equipment you have purchased.
- 2) Hire a technician/ contractor who services customers in your local area and you are familiar with. Local contractors have a faster response time and will be easier for you to determine if they are reputable.
- 3) Use only reputable licensed/ certified HVAC installation contractors/ technicians to prevent any unexpected charges as a result from unethical business practices.
- 4) Check their references, to verify they are a good service provider to the general customers. N.A.T.E or A.C.C.A certified technicians are strongly recommended.
- 5) Some contractors/ technicians may not feel comfortable about installing the equipment that you purchase for them to install, and they prefer to purchase and install the equipment. You can contact YMGI directly to check and see if there have been any contractors in your area who have installed our products or similar.
- 6) Ask for a detailed quote for the whole installation project. A flat rate quote is the safest contract for both you and the contractor
- 7) Your local HVAC technicians may charge you on a project basis or on an hourly basis. To our general knowledge and experience, **a full single head installation may normally cost anywhere from \$800 to \$1500**. These costs are estimates and your actual costs may differ due to job nature and location.
- 8) Number of hours can vary depending upon each individual situation, some factors are, but not limited to:
- 9) How difficult or complex the indoor unit is to be securely installed.
- 10) How difficult or how long the inter-connecting pipes and wires are to be installed.
- 11) If all the suggestions have been taken and all the necessary steps are followed.

CUSTOMER AND TECHNICIAN MUST READ

12) If the contractor(s)/technician(s) are experienced with the systems/brands you purchase.

You might spend less. But remember, many times you get what you pay for.

- 13) Sign a contract with them. The contract should list all the detailed work they will conduct and the standards they will follow. Some contractors are willing to include a 1-year installation/service warranty at no extra charge. Check with them to see if that is available. If available, include that in the contract.
- 14) Verify and confirm the installation is done completely and all the unit functions have been checked and are working properly, all the items in the checklist have been checked and marked well in the warranty registration card/form, prior to paying the contractor in full.

The cost of not having your unit installed properly can be more expensive than spending the little extra money that hiring the right contractor will cost. Protect your investment and warranty eligibility by doing it right the first time.

THE FOLLOWING LISTS THE JOBS AND RESPONSIBILITIES OF THE TECHNICIAN/ CONTRACTOR:

- * Performing a load calculation for the room(s) you would like to air condition. Cooling requirements will be different from the heating requirements. They will consider cooling hours, heating hours and your special needs or requirements. Supplemental heating such as baseboard heater or portable heater may help you save money by not over-sizing or under-sizing the heating equipment.
- * Selecting the right type, size or model of cooling and/or heating equipment.
- * Determining the best location to install the unit. (Positioning indoor unit, outdoor unit and running the inter-connecting pipes/wires.)
- * Selecting the correct electrical components (HVAC circuit breaker or fuse and disconnect switch for the electric power to the outdoor unit, types and sizes of the connecting wires between circuit breaker/disconnect switch and outdoor unit, and the wires between outdoor unit and indoor unit).
- * Keeping the indoor unit away from the ceiling and the outdoor unit away from the wall, bushes and other obstacles at a proper and safe distance to allow for the proper airflow through the unit's.
- * Placing the units on a secured level structure.
- * Taping and sealing both ends of the inter-connecting pipes, before running them through structures, to prevent dust or other debris from getting into the pipes otherwise they will contaminate and damage the refrigeration system. Failure to follow this practice will make your factory warranty void.
- * Connecting the inter-connecting pipes between the outdoor and indoor units. Checking for leaks through pressurization with nitrogen. After releasing nitrogen, evacuate the piping and indoor unit, for removal of system contaminants. Finally refrigerant introduction and adjustment, if necessary, from the outdoor unit.
- * Back-seating the stopping valves at outdoor condensing unit to release pre-charged refrigerant from outdoor unit to indoor unit.
- * Measuring and recording the electrical voltages at different terminals and the refrigerant pressures at stopping valves of outdoor condensing unit.
- * Verifying and ensuring the unit is connected to the proper electrical power supply.
- * Adjusting refrigerant levels (if necessary) following the installation instructions or chart on the unit.
- * Checking for any unusual noises and other abnormalities that might be present.
- * Operating the unit and check all functions, one by one, and explain to the owner how to operate and maintain the unit.
- * Completing all fields in detail on the installer checklist, signing and dating the **Warranty Registration Card/Form**.

LIMITED PRODUCT WARRANTY

If the installation is successfully and fully done by a qualified licensed/ certified HVAC technician/contractor, the registration card/form is filled completely and correctly, and filed along with a valid installation invoice from the contractor company within 7 days of the original installation, the following standard **Limited Product Warranty** is qualified:

5-year on compressor and 1-year other PARTS ONLY. There is **no labor coverage**.



LIMITED PRODUCT WARRANTY POLICIES

The YMGI products are designed and manufactured free from defects in workmanship, and materials for normal use. However, for any reason, including many handlings and occasions between the YMGI factories/warehouses and where you receive the products, the unit doesn't work, YMGI Group will help to remedy the occurrence in the following warranting ways:

Compressor: YMGI will warrant the compressor of YMGI-validated and approved warranty filing, for a period of 5 years from the date of successful installation at original location.

Parts: YMGI will warrant parts of YMGI-validated and approved warranty filing, for one year from the date of successful installation at original location.

All warranty compressors and parts replaced will become the sole property of YMGI Group and must be returned to YMGI Group upon request. Warranty parts may be new or refurbished. All parts are tested and approved before shipping.

At no time does the YMGI Group warrant labor cost of any type. Warranty will start from the date of successful installation at initial location, or 90 days as of original shipping date from YMGI Group, whichever comes first.

This is a standard warranty of limited liability and DOES NOT cover the following:

- * Any damage or repairs to properties, or persons as an incident or consequence of improper or faulty transportation, installation, operation, maintenance or service.
- * Damage caused by frozen or broken water hoses or refrigeration pipes in the event of equipment failure.
- * Any damage as a result of floods, fire, wind, lightening, accidents, corrosive atmosphere or any other conditions beyond the control of YMGI Group.
- * Any damage due to interruption or inadequate electrical service to equipment.
- * Any products that are installed outside the US or Canada.
- * Any unit that has been moved from the original installation address.
- * Any labor costs associated with the installation or service of the unit.
- * Poor unit performance due to improper unit selection (SEER, Unit size).

To validate the above warranties, ALL the following conditions must all be fulfilled:

1. The unit was fully (100%) and successfully installed by licensed or certified HVAC technicians.
2. The unit was installed following all NEC, state and local codes.
3. The unit was installed following all instructions and manuals made by YMGI Group.
4. ALL fields, especially the technician-checklist, of the **Limited Warranty Registration Card/Form** were filled completely by the installing technician and signed by both the installing company technician and the unit owner.
5. The **Limited Warranty Registration Card/Form** and a copy of the original installing company's invoice had been received by YMGI Group-Warranty Dept., POB 1559, O'Fallon, MO 63366, within 7 days of successful installation.

No warranty filing will be validated or approved, if any one of the above 5 conditions is not met.

Product registration doesn't guarantee the validity of this limited warranty statement.

Steps to follow for warranty part replacement:

1. Installing or service technician contacts YMGI tech support at 1-866-833-3138 ext 703 from the jobsite, to double-check and confirm with YMGI Technical support the exact part(s) needed to fix all the problems.
2. YMGI will check the customer's warranty filing. Parts for validated and approved warranty will not be charged. Parts of invalid warranty filing or unapproved warranty requesting, will be charged accordingly.
3. YMGI will ground ship out the parts ASAP. Expedited shipping is available at the customer's cost.
4. Replacement parts of approved warranty registration are to be warranted for the remainder of the 1 year parts and 5 year compressor warranty. Purchasing of replacement parts of invalid warranty filing or unapproved warranty requesting, will be as they are and bear no warranty.

YMGI keeps on improving products with various engineering changes without prior notice. Such improvements or changes include but not limited to product specification, appearance, functions, sizes, packaging and others. These improvements or changes will not void the limited warranty stated herein. YMGI keeps the final explanation of this warranty policy.

LIMITED PRODUCT WARRANTY REGISTRATION CARD



LIMITED PRODUCT WARRANTY REGISTRATION CARD / FORM

YMGI to Fill Top Portion, at Shipping, and Keep Copy A; Center Copy B for Installer to Fill and Mail back to YMGI; Bottom Copy C for Customer to Fill and Keep

For YMGI Use Only	The Company the Unit Was Sold Through: _____		Shipping Packing List Number: _____		Registration Card Serial No. _____	
	Did the Company Pay to YMGI: _____		HVAC Contractor/Technician--Name _____		Date the Filled Registration Card YMGI Received: _____	
	Installation Invoice Attached to the Registration Card _____		Hired YMGI-Recommended HVAC Contractor/Technician? _____		Unit(s) Work Successfully (Yes/No): _____ Warranty Approved _____ Warranty Denied _____	
Outdoor Serial Number (One Outdoor Unit, One Registration Card/Form): _____			Indoor Serial Number: _____	For Multi Zone Units _____	Unit #1 _____	Unit #5 _____
					Unit #2 _____	Unit #6 _____
					Unit #3 _____	Unit #7 _____
					Unit #4 _____	Unit #8 _____
Contact Where the Units are Installed:						
Name: _____				Phone: _____		Fax: _____
Address: _____				Email: _____		
City: _____ State (Province): _____				Country: _____		
Contact of the Installing HVAC Contractor/Technician:						
Technician Full Name (Print): _____				YMGI-Recommended Contractor/Technician:		
HVAC Technician's Company Name: _____				Phone: _____		Fax: _____
Address: _____				Email: _____		
Currently Licensed or Certified HVAC Technician License or Certification Number: _____				License Approved or Certified by: _____		
Official Phone # to Check the License Validity: _____						
List for Installing HVAC Technician to Double Check Installation Quality, and Warranty Processing Purpose (if not filled by technician, or not filled fully, warranty will void)						
1) Are you the only one to install whole system? If not, % of installation done by you (HVAC technician).		2) What had been done, prior to your arrival?				
3) Did you read the User Manual and Installation Instruction, before you started the installation?		4) Who unpacked the unit and accessory boxes to check for damage?				
5) Supply electrical power V/Ph/Hz measured at wiring terminal block of Indoor unit: _____ outdoor unit: _____		6) Incoming electrical power V/Ph/Hz measured at terminal blocks of indoor unit: _____ outdoor unit: _____				
7) Wire gauge, length and terminal colors between circuit breaker/disconnect switch to outdoor unit: _____		8) Wire gauge, length and terminal colors between each indoor and outdoor unit: Unit A _____ Unit B _____ Unit C _____ Unit D...				
9) The size of HVAC circuit breaker/fuse or disconnect switch to the outdoor unit: _____		10) Are the inter-connecting wires and copper lines between indoor and outdoor units installed/covered/protected by line set covers, or anything else?				
11) What is the refrigerant pipe length between each indoor unit and the outdoor unit? Unit A _____ Unit B _____ Unit C _____ Unit D...		12) Where is/are the indoor unit(s) located? Unit A _____ Unit B _____ Unit C _____ Unit D...				
13) What is the elevation difference between each indoor unit and the outdoor unit? Unit A _____ Unit B _____ Unit C _____ Unit D... (indoor unit above outdoor unit +, below -)		14) Did you check the indoor unit for condensate leakage and refrigerant leakage, before and after connecting them?				
15) Where is the outdoor unit located? Ground wall balcony roof other _____ Is the outdoor unit anchored to ground or secured onto wall location or pad _____ bracket?		16) Have you checked to make sure there is no cross-piping and no cross-wiring between any two indoor units (zones)? How did you do it, who was with you?				
17) Were the refrigerant pipe ends capped or taped seal, prior to running them through structures to keep debris from entering the copper lines?		18) Have you checked and run cooling or heating, one unit by one unit, all working fine?				
19) Did you charge the inter-connection copper pipes and indoor unit with nitrogen to check for positive leakage (pressures 150-200PSI), before conducting vacuuming leakage check?		20) Did you vacuum correctly to check the connecting pipes and indoor unit for leakage, what was the micron gauge reading, for how many minutes?				
21) Did you check if the compressor can be started and stopped in a correct (design) manner?		22) If copper length were not made to the supplied or recommended refrigerant pipe length, how much refrigerant added or deducted?				
23) Measured refrigerant pressures at outdoor service suction valve, when unit was st. Heat pump (PSI): _____ Cooling (PSI): _____ Outdoor Ambient Temp. (°F): _____		24) What were the measured temperatures (probe not touching any metal): At cooling: indoor return air °F, discharge air °F, and outdoor °F At heating: indoor return air °F, discharge air °F, and outdoor °F				
25) Have you checked all unit functions, with customer's witness, and all functions are correct?		26) Did you show the user how to operate the unit? Did he/she understand you?				
27) Do you provide regular one-year free technical service for this installation?		28) Do you list the working details in the invoice and leave a copy to the customer?				
Installation Finished and Unit Works Successfully. Print Name of Installation HVAC Technician: _____ Signature: _____				Installation Finished and Unit Works Successfully. Print Name of Owner: _____ Signature: _____		
Date and time: _____				Date and time: _____		
By signing above, I acknowledge the liability and responsibility for any false statement or not telling all the facts, and I authorize YMGI to check the details of the filled above, and make its decision on warranty. I understand our filing or filling the warranty card/form DOESN'T mean automatic warranty approval, because warranty is approved only to those qualified and successful installations by qualified HVAC technician. I know the warranty, if approved, is a standard 5-year compressor and 1-year other parts only, without any labor coverage. I agree to and will follow all the contents contained in the Limited Product Warranty Policy that YMGI, not other entity, stated in public, including but not limited to manuals, web site, email, etc.						
Important Note: A copy of the installing HVAC company's invoice to show all their work details, your payment proof, center copy B of this registration card filled after a successful installation, all three (3) MUST be mailed together to Warranty Dept., YMGI Group, POB 1559, O'Fallon, MO 63366, for warranty processing. Customer keeps bottom copy C. YMGI will check against copy A that was kept at YMGI.						

MUST READ

MUST READ



CUSTOMER AND TECHNICIAN MUST READ

PRIOR TO OPENING THE BOX OF, OR INSTALLING / SERVICING THE PRODUCT (HVAC & R)

Upon the purchasing, unpacking, installation and/or service of this product, you and all other parties hired to install or service your products, have read all YMGI Group (we) has written hereafter and all agree:

- 1) You understand all that is written hereafter in this and other documents that we publish.
- 2) You will follow what is written hereafter in this and other documents that we publish.
- 3) You will be bound by and completely follow all policies, guidelines, instructions, warnings, attentions and other materials, as published by YMGI Group, its subsidiaries or sister companies, in writing.
- 4) Only a successful installation, fully (100%) conducted by a qualified HVAC technician(s), as detailed in the checklist of the **Limited Product Warranty Policy** and **Limited Product Warranty Registration Card/Form**, along with a properly detailed installation invoice, is eligible for the **Limited Product Warranty**.
- 5) Failure to follow what is written hereafter may cause various equipment issues that you will take full responsibility and liability for, including, but not limited to, losing manufacturer's warranty, unit not working properly, unit malfunctions, under-performance, decreased safety, increased potential of various damages to your property, body, home and/or business, etc.
- 6) YMGI documents and policies supersede those made or provided by the sales distributors or installing contractors. YMGI Group maintains the final authority in explaining and resolving any and all discrepancies that might exist between distributors/contractors' documents and ours.

YMGI STRONGLY RECOMMENDS:

- * Customer hires a currently licensed/ certified HVAC technician(s) (N.A.T.E. or A.C.C.A certification is strongly recommended) to conduct 100% of the installation, inspection of all unit functions and repair service.
- * Customer signs an installation/service contract with the installation/service technician's company who has good service references and you trust. Installation and service is very important to the life of your investment and provide you a lifetime of comfort and peace of mind.
- * Customer requests the installer to put down a 1-year labor warranty coverage in the installation contract.
- * Have the technician check against all the items in the checklist of the **Limited Product Warranty Registration Card/Form**, sign and date it, to help ensure a proper and professional installation.
- * Customer pays in full, only after all the unit functions are inspected, the unit works properly, warranty checklist is fully filled out and signed and you are fully satisfied.
- * If any unit abnormality is found, have your technician check the unit first. Have them call for manufacturer technical assistance, if necessary, from your job site, not his office, so that we can more accurately assist him in diagnosing the cause of the malfunction.

CUSTOMER AND TECHNICIAN MUST READ



ATTENTION

- 1) The YMGI **Limited Product Warranty Policy**, details the eligibilities, coverage's and other explanations of the warranty terms between YMGI group and the unit owner.
- 2) The YMGI **Limited Product Warranty Policy** and the **Warranty Registration Card/Form** are either included inside the user's manual and/or installation instruction manual, or come separately in the unit packaging box/envelope. If for any reason they are not included with your shipment, contact our sales or customer service to request a copy (electronic or printed), prior to installation.
- 3) The checklist, in the **Warranty Registration Card/Form**, is for the currently licensed/ certified HVAC technician to fill out completely, while verifying all unit functions are operating correctly. This checklist is for the technician to test and check all details of your unit, to verify and ensure its proper operation.
- 4) The technician must complete all fields in the **Warranty Registration Card/Form**, especially the unit model and serial numbers and distributor information, and most importantly, the technician checklist.
- 5) **Warranty Registration Card/Form** shall be mailed, **along with the original copy of the currently licensed HVAC contractor's full installation invoice**, to YMGI Group, within 7-days after original installation, in order for YMGI to review and process your warranty registration.
- 6) Keep a copy of **Warranty Registration Card/Form** for your own use in the future, to aid in any possible future warranty claiming, any request of parts, customer service, and/or technical support.
- 7) YMGI reserves the right to approve or deny the warranty status based on the information reviewed.

Mailing address of the **Warranty Registration Card/Form**: Warranty Department, YMGI Group, POB 1559, O'Fallon, MO 63366, USA.

Following these requirements will aid in ensuring the units will be installed to the general HVAC practicing standards and are necessary factory requirements, to find problems early, prevent possible damage to the unit and help ensure the unit will work properly for its life time.

QUESTIONS ABOUT SELF-INSTALLATION VS HIRING LICENSED HVAC TECHNICIANS

Does YMGI allow to do-it-yourself installations (DIY) partially or fully? NO.

Unfortunately no brand or manufacturer can take the responsibility of the equipment if it is not professionally installed by a currently licensed HVAC technician/ contractor.

If unit is installed by non-licensed people, in part or fully, will the factory warranty be void? YES.

Some DIY installations have been successful, but these are exceptions. Most have resulted in equipment failure, due to lack of knowledge and experience. A few of the problems result from DIY's lack of knowledge in the following areas:

- * Sizing and selecting correct type, size and model of cooling and/or heating equipment.
- * Sizing and installing correct electric circuit breakers and wires.
- * Wiring the units correctly and properly.
- * Taping the ends, connecting to indoor and outdoor units correctly and properly.
- * Vacuuming the inter-connecting refrigerant lines.
- * Checking and/or fixing the refrigerant leaks.
- * Checking and/or fixing the condensate drain leaks.
- * Releasing the refrigerant from outdoor unit to indoor unit.
- * Running the unit to check all the unit functions.
- * Conducting the installation or trouble-shooting with correct tools, experience or professional knowledge to correct the problem.

RECEIVING AND FREIGHT DAMAGE

- * Freight (package/unit) shall be checked thoroughly for damage at receiving before accepting by signing on the carrier's delivery paperwork.
- * Upon shipment being signed for acceptance, it becomes a binding document as to the condition of the products on delivery. We cannot process any shipping damage claim, if you accept the delivery.
- * If damage is found at delivery, both you and the delivery driver must make notes on the delivery receipt or other freight paperwork detailing the damage found by marking position/parts on unit, description of damage, time/ date, your name, contact phone, etc. on the delivery documents. Make a copy of the marked delivery receipt.



CUSTOMER AND TECHNICIAN MUST READ

- * If the damage is minor or partial, that you choose to accept, you can contact the distributor or YMGI to discuss the possible replacement of the damaged part.
- * If refusal of the shipment is needed due to severe freight damage, **DO NOT** sign the carrier's delivery receipt document indicating that you accept the products. Mark receipt "REFUSED DUE TO FREIGHT DAMAGE." Sign and date along with the delivery driver's signature and date.
- * Take pictures showing the damage, before the delivery driver leaves.
- * If you accept the delivery or fail to note damage on the driver's delivery receipt, the ability to claim freight damage is lost and YMGI will not replace the unit on this basis.
- * Contact the distributor or YMGI, report the damage by forwarding the marked delivery receipt copy and pictures.
- * Only after YMGI verifies with the carrier the necessary detailed notes of received freight damage, will the damaged products be eligible for replacement.
- * If the returned products are found not damaged, YMGI will treat it as a return and will charge you 25% of product value plus added shipping cost.

RETURN-YMGI GROUP POLICIES & RETURN GOODS AUTHORIZATION (RGA)

All sales are final. If the customer wishes to return a product, the following **Return Policies** apply.

A. Only those products (units, parts or accessories) under the following conditions, are eligible for return:

1) Products are returned within 30 days of their original shipment date from YMGI

- 2) Products have not been installed.
- 3) No damage exists on the products being returned.
- 4) No missing products.
- 5) Products and packages are clean.
- 6) No duct tape or marking on the product or box.
- 7) Products are still their original package, in good shape and in re-sellable condition, as YMGI determines.

B. Preapproval steps for your return request:

- 1) Contact your distributor or YMGI to request a return.
- 2) Photograph your product and box to show details
- 3) YMGI will review your request, along with the pictures and any other details pertaining to your request.
- 4) If YMGI agrees to process your return request, a form called **Return Goods Authorization (RGA), along with an assigned RGA #** will be forwarded to your distributor or you.
- 5) Any return without YMGI Group approved RGA#, will not be accepted.

C. YMGI must verify the following before you can pack your products:

- 1) No products (units, parts, accessories) are missing.
- 2) No damage is found.
- 3) The products are in the original packaging.
- 4) No duct tape on any product or box.
- 5) Pictures have been taken and sent to YMGI to verify the product and boxes are not damaged.
- 6) The RGA has been completed and a copy has been returned to YMGI, via email or fax.
- 7) YMGI has approved the request in writing.

D. Shipping Preparation:

- 1) Package all products in a manner in which no damage can occur to the product and secure to a pallet.
- 2) Take and forward pictures of packed pallets for YMGI to verify proper packaging and no existing damage.
- 3) Include the YMGI approved RGA# in the shipping documents.
- 4) YMGI reserves the right to approve or deny any shipments.
- 5) YMGI can arrange shipping for you, but not at YMGI's cost. If this option is chosen, a packing list and BOL will be issued to you through YMGI.
- 6) If the above option is not chosen, you will be responsible for all freight charges. YMGI will not accept any returned items COD.
- 7) Place the package in an area which is accessible to the shipping company for pickup and limits the possibility of damage to the product. Customer must be present at the time of freight pick up.

After shipping, fax the BOL to YMGI Group at 1-866-377-3355 or email to customerservice@ymgigroup.com, detailing the information of the freight company and their tracking number.

E. Freight Damage:

- 1) YMGI Group will inspect returned items
- 2) Claiming of freight damage from a customer hired carrier will be the customer's responsibility.
- 3) Claiming of freight damage from a YMGI hired carrier will be YMGI's responsibility.

CUSTOMER AND TECHNICIAN MUST READ

F. Charges for your return:

- 1) A restocking charge of 25% creditable invoice value.
- 2) All return shipping fees.
- 3) Additional fees will be charged, if products are found to be damaged, missing or used.
- 4) YMGI will notify the distributor of the charges only after the inspection and assessment of the returned products has been completed.

Attention:

- 1) Returned products must be shipped within 7 days of YMGI's releasing of **RGA #**.
- 2) **All RGA** shipping shall be prepaid by the customer. **YMGI will not accept any COD freight.**

YMGI GROUP DISCLAIMING-1:

YMGI Group will NOT accept any return, or may not honor 100% credit for any return of Product(s)/Part(s)/Accessories, in any of the following cases:

- * Return requests made 30 or more days after the date of original sales shipping from YMGI Group warehouse.
- * Return shipment is initiated 8 days or more after the RGA is approved.
- * Returned products received not displaying an YMGI-approved valid **RGA #**.
- * Returned products received C.O.D.
- * Returned products not received in the original packaging.
- * Returned products received with non-repairable packaging, including duct tape or marks on units or carton boxes.
- * Returned products received with missing units/parts/accessories.
- * Returned products received, are found to be non-functional or damaged.

YMGI GROUP DISCLAIMING-2:

- * YMGI Group will not be responsible for any losses of returned unit(s)/part(s)/accessories in transition to YMGI Group warehouse.
- * YMGI Group RGA is valid for seven (7) days from the original issuing date. Returns will not be accepted, if shipping is made 8 or more days after the YMGI Group RGA is issued.

DEFECTIVE UNITS / PARTS / ACCESSORIES-REPAIR OR REPLACEMENT

Out of thousands of units sold every year, there may be an occasional instance your product does not operate properly. Reasons of but are not limited to: **manufacturing, installation, operation, maintenance and knowledge of operator.**

Equipment failure does not automatically denote a product defect from the factory assembly line. The defects can be caused, during production, transportation, installation, operation, maintenance, or service. Defects may NOT be the responsibility of the manufacturer. Nobody willfully or intentionally produces a defective product. No determination shall be made until the technical issue(s) or the causes of the defect(s) are identified.

The defects might be found before/ during installation or in the operation of the unit. Defects can be in the form of blown fuse(s), defective control board(s), damaged remote control, loose or missing screws, etc. These defective parts can be replaced easily.

Some functions of our units are different from what are typical in traditional split type air conditioning and heat pump systems and similar systems made by other manufacturers. These are not defects. Take some time to learn the functions of your unit. We will be happy to assist you with any questions you may have concerning the functions of your new unit.

If a defect is found, whether at the original installation, or during normal operation, we will gladly help you in the following steps in sequence from 1 to 3:

1. **Part repair or replacement after trouble-shooting:** This is the most common and generally the easiest and most economical way for all parties, since the problem and all part needs can be accurately and completely identified.

- * Your technician calls our technical support line, from your job site, after checking your units and getting all the information ready.
- * Our technical support will go through several steps, over the phone or through email, with your technician, in order to help identify and resolve the problems. Normally wiring correction, piping correction, part repair/ replacement will resolve the problems.



CUSTOMER AND TECHNICIAN MUST READ

* Your technician will then need to verify and confirm the problem(s) before YMGI can ship out the replacement part(s). Inaccurate or incomplete troubleshooting or part replacement will delay the repair. YMGI technical support will only speak with a licensed/certified technician in regards to the repair of your unit. In our experience this saves time and money for all parties involved.

Your technician is the only person to perform any physical checking, trouble-shooting and replacing of any defective part(s) for your units. Our factory technical support is just a help. **YMGI provided no labor warranty on the products.**

2. Unit/part repair at our workshop(s): Due to the limitations of our technical support not being at your job site, or your technician's experience with our product, the problem may not be resolved as quickly as would be desired. If the problem is still not resolved after attempts between your technician and our technical support, you can elect to have the unit repaired at our facility. If this step is chosen:

- 1) YMGI will send to you the **Customer Request to Ship Products to YMGI Service Center for Inspection and Repair, and Authorization to Charge** form.
- 2) You will review the form and fill all fields appropriately, sign and send back to the YMGI Group.
- 3) Once the form has been completed and sent back to YMGI, remove the units and ship back to YMGI.

Please make a note describing the problem and communication history, if possible. Our technicians will check the units and find the problem(s), repair the issue(s), and ship the unit back to you following the conditions set forth in the signed repair agreement. All unit removal and re-installation is done at your cost and must be done by a currently valid licensed HVAC technician.

3. Unit replacement: Only applies to those defects reported within 30 days of original purchase date and if all necessary warranty paperwork had been received and approved. This option applies only if the above steps cannot resolve the problem(s). Either indoor or outdoor unit replacement is available, based on the actual need, at YMGI's determination. ***This option shall be the last resort,*** due to refrigerant and wiring considerations. All unit removal, re-installation and shipping cost are the responsibility of the customer. YMGI maintains the final authority as to unit replacement. Replacement will be made with the same model only. Alternate units will be treated as a new order.

Returning Replaced Defective Units/Parts/Accessories After Unit Repair: (Only applies to steps 1&3 above)

- 1) Repack the replaced unit/ part /accessory in the box which contained the replacement part.
- 2) Parts can be boxed for UPS, FedEx or equivalent ground service. Units shall be secured onto the skid on which the replacement was shipped after placing into the package from the replacement product.
- 3) Ship **all** replaced products, to YMGI-designated location. You will be charged if YMGI does not receive the replaced parts.

Standard factory warranty does not cover the cost of materials and labor that are incurred at your site. There will be no cost for the replacement unit, if YMGI determines the defect is manufacturer related. Replacement will be made with the same model, only. Alternate units will be treated as a new order.

CUSTOMER SERVICE / TECHNICAL SUPPORT FROM YMGI GROUP

For questions or help with your unit, contact the original installer or service provider.

YMGI Group does not install nor physically service your unit. Your installer or service provider must check the unit prior to contacting YMGI Group from your jobsite, in order to be helped in an efficient and timely manner.

* Factory customer service at customerservice@ymgigroup.com Tel: 1-866-833-3138x704

* Factory technical support at techsp@ymgigroup.com Tel: 866-833-3138x703

* Fax: 1-866-377-3355

An "**YMGI Group Customer Service/Technical Support Daily Log Sheet**" will be filed in writing at our office, for effective communication between you and YMGI Group customer service, your technician and YMGI Group technical support. Before contacting the YMGI Group locate the IP# written at the top of your warranty registration form. Use this IP# whenever you contact the YMGI Group.



DISTRIBUTOR AND MANUFACTURER POLICIES



- * All questions concerning sales or money will be directed to the sales distributor from which you purchased the units.
- * Read and follow all policies set forth from the distributor from which you purchased your unit.
- * Upon purchase and installation of the unit(s), you agree to be bounded by all policies published by both distributors and YMGI.
- * MGI Group has the final authority and supersedes other related parties (distributors, etc.) concerning all policies regarding YMGI products.

IMPORTANT NOTES

SAFETY WARNINGS

READ THESE SAFETY WARNINGS COMPLETELY PRIOR TO ANY USE.

	Ground connection
	Disconnect the plug

	Forbidden
	Imperative

These precautions are essential and must be strictly observed.

DO NOT pull on the power cord or refrigeration lines. Install them in a secured position. A line set plastic cover is recommended.

DO NOT install the unit in places where there is exposure to flammable materials or gas leakage.

DO NOT use wire or circuit breakers that do not meet electrical safety standards. Several circuits cannot be connected to one breaker.

DO NOT wire or open the unit while it is running. Make sure to shut off all circuits prior to inspecting or servicing the unit.

DO NOT install unit in a damp laundry room or near flammable gas. All units must be protected by certified electrical circuit breakers and in accordance with all safety codes.

DO NOT use the unit in cool or dry mode for prolonged periods where humidity is higher than 80%.

DO NOT install the indoor unit close to cooking surfaces or ventilation systems. Poor placement could inhibit peak performance.

DO NOT blow cold air directly towards people for extended periods. It may get you a bad cold.

DO NOT use chemical solvents, flammable insecticides, or abrasive materials. Clean the unit only with a soft dry cloth or rag.

DO NOT continue to operate the unit if there is any abnormal odor, burning, scorching, or smoke. Stop and disconnect the unit immediately.

DO NOT use the system for anything other than what it was designed for or any non-HVAC purposes. Do not store near food, paint, or other chemicals.

DO NOT operate the unit for prolonged periods without refreshing ambient air. Opening a door or window periodically will suffice.

ELECTRICAL SAFETY

⚠ WARNING

Shall install or make sure to select the correct size of circuit breaker or fuse.

If LCDI Cord/Plug is required, need to make sure the right size of LCDI is selected.

Extra Electrical Safety: LCDI Cord/Plug (Optional Part)

Other than the circuit breaker, LCDI Cord/Plug provides additional safety. It will interrupt the circuit in case the current leakage exceeds allowed amount.

Test and Reset Buttons are made for each LCDI. If pressing the Test Button, the circuit will trip; to resume the circuit, press Reset Button. It is recommended to check the two buttons periodically to make sure they work properly. If anything wrong is found at the LCDI, it shall be replaced without any delay.

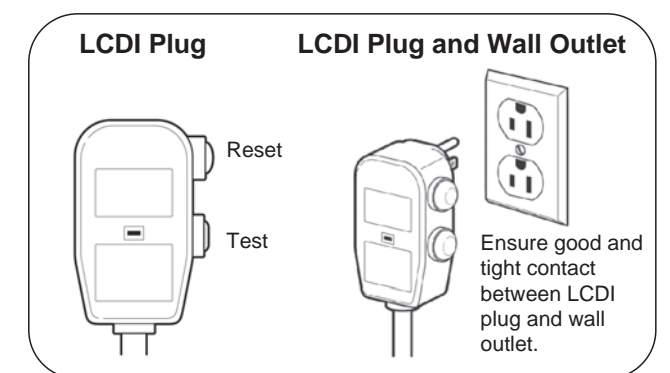

WIRING SIZE & CIRCUIT BREAKER

MODEL NO.			WMMS-09K-31A (P4)	WMMS-12K-31A (P4)	WMMS-09K-32A (P4)	WMMS-12K-32A (P4)	WMMS-09K-34A (P4)	WMMS-12K-34A (P4)	WMMS-09K-34B (P4)	WMMS-12K-34B (P4)
THERMAL MODE			AC ONLY		Heat Pump		Heat Pump + Aux. Heater		HP + Back-Up Heater	
INPUT POWER SOURCE			A: 115/1/60 F: 220/1/50						B: 208-230/1/60 F: 220/1/50	
MCA	FOR WIRE SIZING	AMP	15	18	15	18	20	20	20	20
MINIMUM WIRING SIZE	LENGTH OF LESS THAN 15 FT	AWG	14				12			
HVAC CIRCUIT BREAKER	FOR FUSE SIZING	AMP	20	30	20	30	30	30	30	30



IMPORTANT NOTES

RECOMMENDED UNIT OPERATION TEMPERATURE RANGES

Recommended operation temperature ranges for this unit as follows:

COOLING

Indoor side: dry-bulb 64-90°F RH 0-95%

Outdoor side: dry-bulb 45-104°F RH 0-95%

If this unit is fully counted on for heating in below freezing point for a long time, suggest to select the models with electric backup heater.

If the model is not in stock, shall select other sources/means for back-up heating.

HEATING

Indoor side: dry-bulb 45-86°F RH 0-95%

Outdoor side: dry-bulb 35-80°F RH 0-95%

A PIECE-OF-CAKE WMMS(P)-Quality of Features

PC BOARD

PC board is built with high quality components and dual layers printing technology.

FUNCTIONS

Auto, Cooling, Heating, Dehumidifying (Dry).
Sleep Timer, Auto Restart, Defrost, Cooling or Heating Booster.

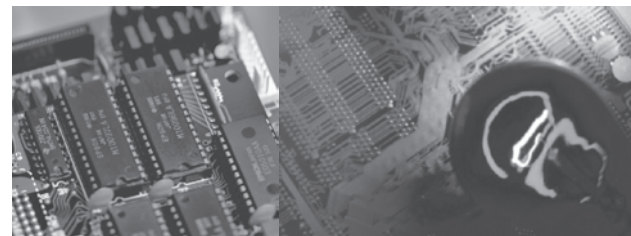

LOW NOISE

The unit is designed and manufactured for super quiet acoustic performance.

REMOTE CONTROL-EVERYTHING IS UNDER CONTROL

- 1) Remote control can control all the functions, including modes, temperature, fan speed and other functions.
- 2) Remote control should be put in the wall bracket holder if not used.
- 3) Room temperature is shown on the front control panel. After set temperature or other operation mode is selected it will show the current room temperature.



HEALTHY ENVIRONMENT

Active carbon filter purify the room air, create healthy and comfortable environment.

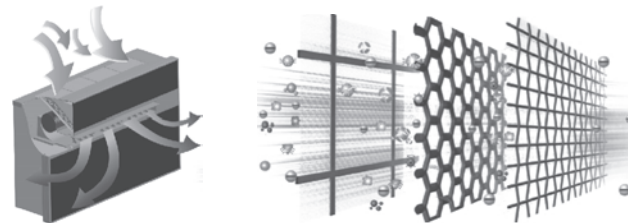

EASY FILTER CLEANING

Check filter from time to time to make sure they are clean. Filter can be taken out of room air inlet frame easily by pressing the latch handle at filter end. The filter is washable. Make sure it is dry before putting them back.

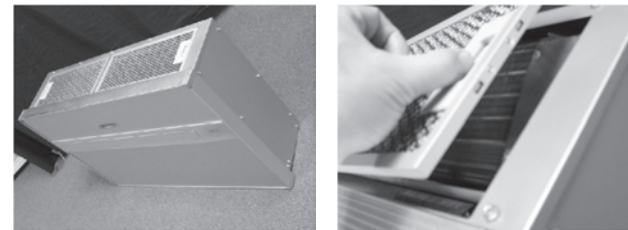

ACTIVE CARBON FILTER AND ION GENERATOR IMPROVING LIVING ROOM AIR QUALITY

Because the active carbon filter can filter impurity deeply, the air flow speed needs to be treated specially.

Room air passes through basic active carbon filter, smell and smoke are extracted, Ion generator starts and ions are released.

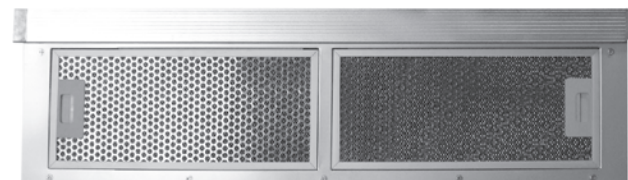

A PIECE-OF-CAKE WMMS(P)-Performance Curves (For Reference)

PERFORMANCE-COOLING

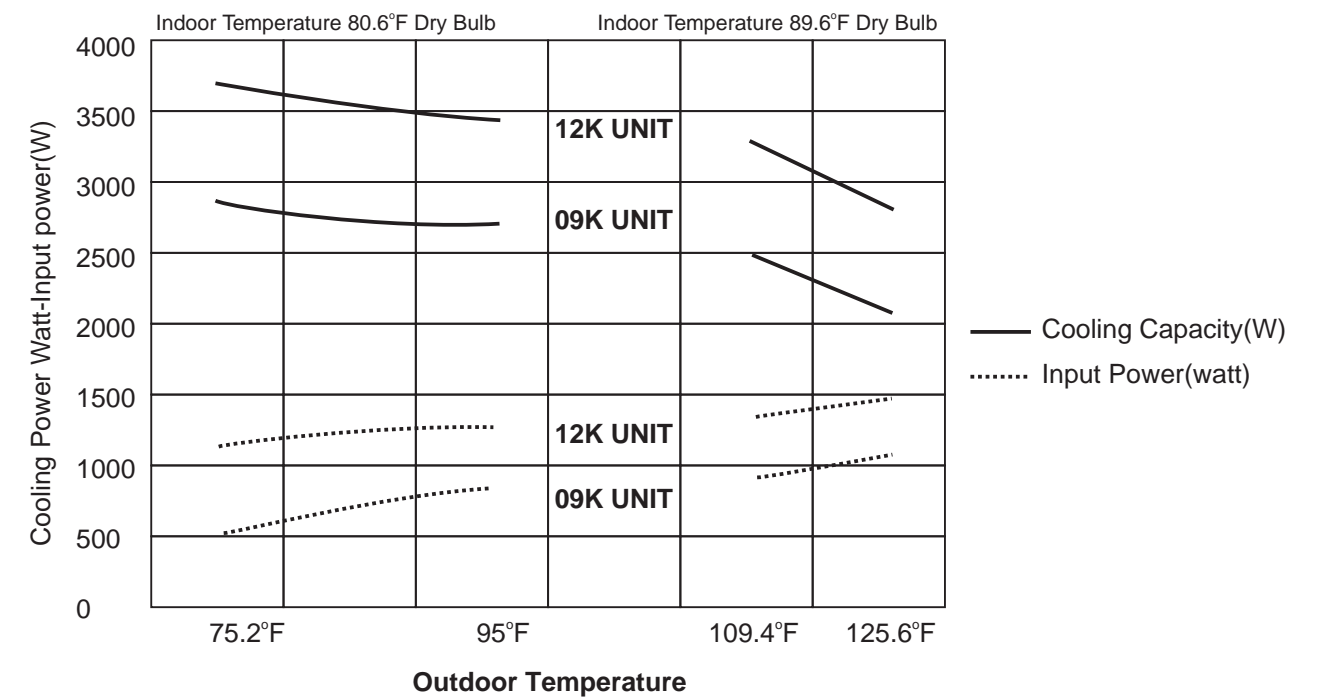

This unit is designed only good for T1 weather.

The above graphs show the cooling performance during tests in ambient temperature of 125.6°F or below.

PERFORMANCE-HEATING

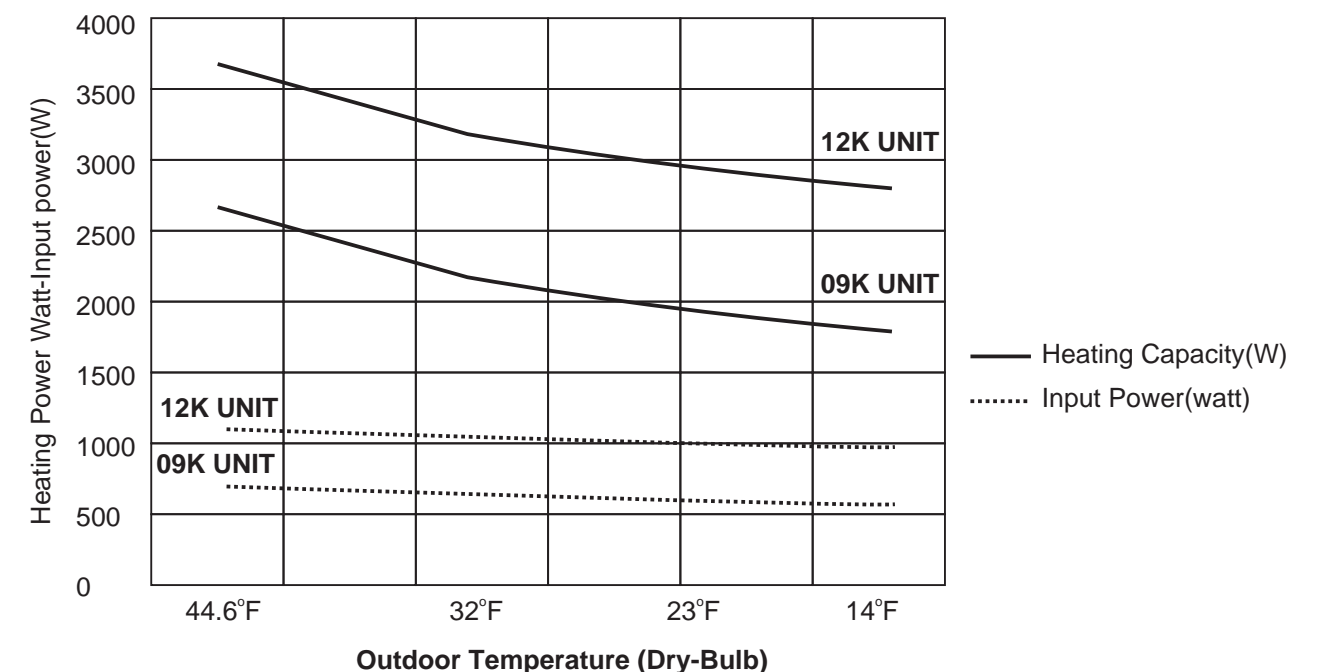

Note: Heating performance tested without ele. heater.

A PIECE-OF-CAKE WMMS(P)-Brief Specifications

BRIEF UNIT SPECIFICATIONS

MODEL NO.			WMMS-09K-31A(P4)	WMMS-12K-31A(P4)	WMMS-09K-32A(P4)	WMMS-12K-32A(P4)	WMMS-09K-34A(P4)	WMMS-12K-34A(P4)	WMMS-09K-34B(P4)	WMMS-12K-34B(P4)
THERMAL MODE			AC ONLY		Heat Pump		Heat Pump + Aux. Heater		HP + Back-Up Heater	
COOLING CAPACITY	Rated ID 80/67F OD 95F	BTU/H 1), 2)	9000	12000	9000	12000	9000	12000	9000	12000
HEATING CAPACITY	Rated ID 70/60F OD 47F (17F)	BTU/H 1), 2)	N/A	N/A	9500(5000)	12800(6800)	9500(5000)	12800(6800)	9500(5000)	12800(6800)
ELECTRIC HEATER	RATED	WATTS	N/A	N/A	N/A	N/A	1500-1800	1500-1800	2400-3000	2400-3000
DEHUMIDIFICATION	RATED	PTS./DAY	42.2	48.6	42.2	48.6	42.2	48.6	42.2	48.6
SEER	RATED	BTU/H.W	13	13	13	13	13	13	13	13
HSPF	RATED	BTU/H.W	N/A	N/A	8.1	8.0	8.1	8.0	8.1	8.0
SOUND LEVEL (POWER)	INDOOR/OUTDOOR	dB(a)	22-23/36-38	22-23/36-38	22-23/36-38	22-23/36-38	22-23/36-38	22-23/36-38	22-23/36-38	22-23/36-38
REFRIGERANT	PRE-CHARGED	YES	R410A	R410A	R410A	R410A	R410A	R410A	R410A	R410A
INPUT POWER SOURCE			A: 115/1/60 F: 220/1/50				B: 208-230/1/60 F: 220/1/50			
POWER CONSUMPTION	COOLING	WATTS	960	1130	960	1130	960	1130	960	1130
	HEATING	WATTS	N/A	N/A	920	1095	920	1095	920	1095
TOTAL CURRENT	COOLING	AMP	8.9	9.8	8.9	9.8	8.9	9.8	4.5	4.9
	HEATING	AMP	N/A	N/A	8.0	9.5	8.0+5.0	9.5+5.0	4+10.4	4.7+13.0
MCA	FOR WIRE SIZING	AMP	15	18	15	18	20	20	20	20
MINIMUM WIRING SIZE	LENGTH OF LESS THAN 15 FT	AVG	14				12			
HVAC CIRCUIT BREAKER	FOR FUSE SIZING	AMP	20	30	20	30	30	30	30	30
INDOOR FAN MOTOR	FAN	TYPE	CROSS-FLOW							
		CFM	230/265/300	230/265/300	230/265/300	230/265/300	230/265/300	230/265/300	230/265/300	230/265/300
	MOTOR	RATED WATTS	14-15	14-15	14-15	14-15	14-15	14-15	14-15	14-15
		MAX. SPEED	1350	1350	1350	1350	1350	1350	1350	1350
OUTDOOR FAN MOTOR	FAN	TYPE	CENTRIFUGAL							
		CFM	1175	1175	1175	1175	1175	1175	1175	1175
	MOTOR	STYLE	PSC							
COMPRESSOR	HERMETIC	BRAND	TOSHIBA OR PANASONIC OR HITACHI OR EQUIVALENT							
CONTROL	THERMOSTAT CONTROL	REPLACING PCB	OPTIONAL	OPTIONAL	OPTIONAL	OPTIONAL	OPTIONAL	OPTIONAL	OPTIONAL	OPTIONAL
	REMOTE CONTROL	INCLUDED	Yes	Yes	Yes	Yes	Yes	Yes	Yes	Yes
	LOW AMBIENT CONTROL	INCLUDED	Yes	Yes	Yes	Yes	Yes	Yes	Yes	Yes
	DEFROST ON DEMAND	INCLUDED	Yes	Yes	Yes	Yes	Yes	Yes	Yes	Yes
CONNECTIONS	ANTH-CHE	INCLUDED	ID/OD	ID/OD	ID/OD	ID/OD	ID/OD	ID/OD	ID/OD	ID/OD
	DRAINAGE	DRAIN PIPE	1/2"ID 3/4"OD							
	WIRES	OPEN STRIPPED END	3 Ft.	3 Ft.	3 Ft.	3 Ft.	3 Ft.	3 Ft.	3 Ft.	3 Ft.
LCD I		OPTIONAL	OPTIONAL	OPTIONAL	OPTIONAL	OPTIONAL	OPTIONAL	OPTIONAL	OPTIONAL	
AIR PIPES-ROUND INTAKE / EXHAUST	DIA./MAX. FT.	8 INCHES / 25 Ft.								
LOUVER-INTAKE / EXHAUST	TYPES	STANDARD-ROUND PIPE / EXTERIOR. OPTIONAL-ROUND PIPE-RECTANGULAR EXTERIOR								
INSTALLATION	LIMIT-HIGH (TOP TO GROUND)	FT	8	8	8	8	8	8	8	8
	LIMIT-LOW (TOP TO GROUND)	FT	0	0	0	0	0	0	0	0
INSTALLATION KIT	AIR-FLOW PIPES	INTAKE / EX-HAUST	1/1							
	GRILLES	INTAKE / EX-HAUST	1/1							
WORKING AMBIENT TEMPERATION RANGES (AC / HP)	F	45-104 / NA		45 to 104 / 35 to 80		45 to 104 / 35 to 80		45 to 104 / 35 to 80		
WEIGHT	NET	LBs	104	106	104	106	104	106	104	106
	GROSS	LBs	112	118	112	118	112	118	112	118
DIMENSION WxHxD	UNIT	INCH	37 x 24 x 10							
	BOX	INCH	39 x 26 x 12							
LOADING CAPACITY	20/40/40'HQ	SETS	130/260/312							

NOTES:

- 1) Electric data above is based upon 60HZ. For data of 50 HZ, look up in the nameplate on the unit.
- 2) Performance rated for matched system at standard conditions-cooling ID 80/67F, OD 95F, heating ID 70/60F, OD 47/43F. Unit performance varies when weather changes from the standard one.
- 3) Select equipment capacity sizes per space load calculation schedule and cooling & heating hours. Not to over size or under size equipment.
- 4) Watch unit operation during extreme weather conditions in summer and winter. After the unit is used for quite a while in these weather, unit may step into protection mode and stay idle.



ADVANTAGES OVER TRADITIONAL SYSTEMS

EASIER & QUICKER INSTALLATION



A-Piece-of-Cake AC/Heat Pump
Installed inside room on the
wall-small exposure.



Split type air conditioner and window type air conditioner.
Installed on exterior **wall-big exposure.**

VS

ELEGANT & AESTHETIC LOOKING INSIDE & OUTSIDE



VS



Now more and more countries have strict rules to forbidden outdoor installation to ensure better safety and aesthetic effect.



Window type: noisy

Split type: not easy to install and maintain

Portable type: convenient but noisy

A PIECE-OF-CAKE WMMS(P): elegant, low noise, easy installation and maintain.

A PIECE-OF-CAKE WMMS(P) gets rid of all the problems and brings up great comfort and the best performance.

*** 2 Holes & 1 Wall Mount, The Only One on the Rock**

*** 2 Men & 1 Hour Installation, A Piece of Cake**



UNIT INSTALLATION

PARTS & LIST OF ACCESSORIES

- 1 Wall Mount BRACKET
- 2 REMOTE CONTROL
- 3 REMOTE CONTROL HOLDER (OPTIONAL)
- 4 DRAINAGE HOSE
- 5 CONDENSATE HOSE EXTENSION (OPTIONAL)
- 6 EXTERNAL GRILLE
- 7 DISCHARGE AIR DUCT (OD7.7"*L10")
- 8 INTAKE AIR DUCT (OD7.7"*L10")
- 9 1:1 SCALE PAPER TEMPLATE FOR WALL MOUNT DRILLING
- 10 INSTALLATION, OPERATION & MAINTENANCE

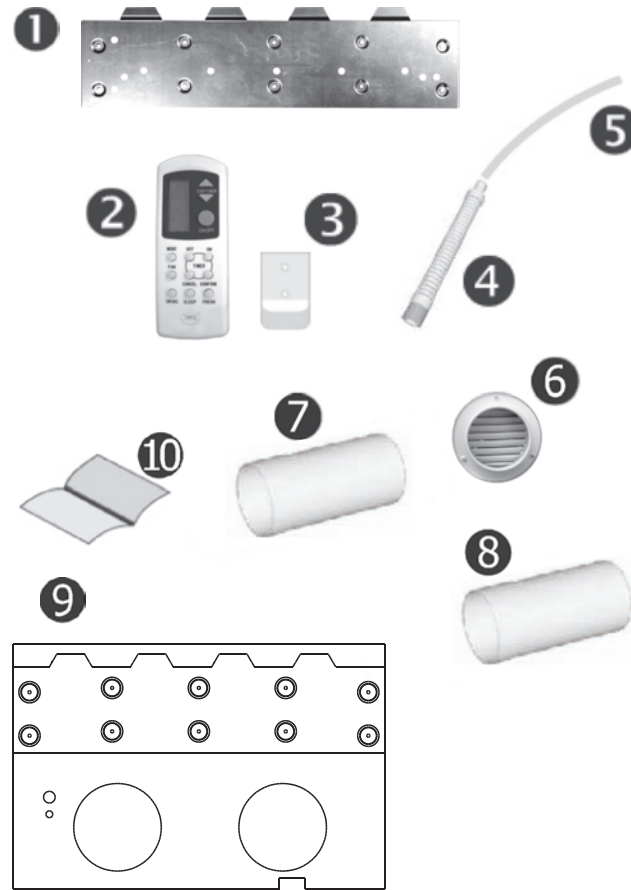

POSITIONING THE UNIT

To maintain the best performance from the unit, prevent breakdowns or hazards, you must position the unit correctly. Follow the guidelines and instruction below in full, as failure to do so could cause potential installation problems.

- * The air conditioner must be installed where 6.6 feet clearance at both indoor and outdoor discharge air sides.
- * The wall on which the unit is installed must be sturdy enough to withstand the operational weight of the unit.

After determining the best place for installation check to ensure that the wall can be drilled where without interfering with other structures or installations (beams, piers, pipes, wires, etc.).

Must ensure that there are no obstacles on the outside of the wall, which may obstruct air circulation through the drilled holes, for example: plants and their leaves, slats or panel, drain pipes, overflows and gratings, etc.). Any obstruction could.

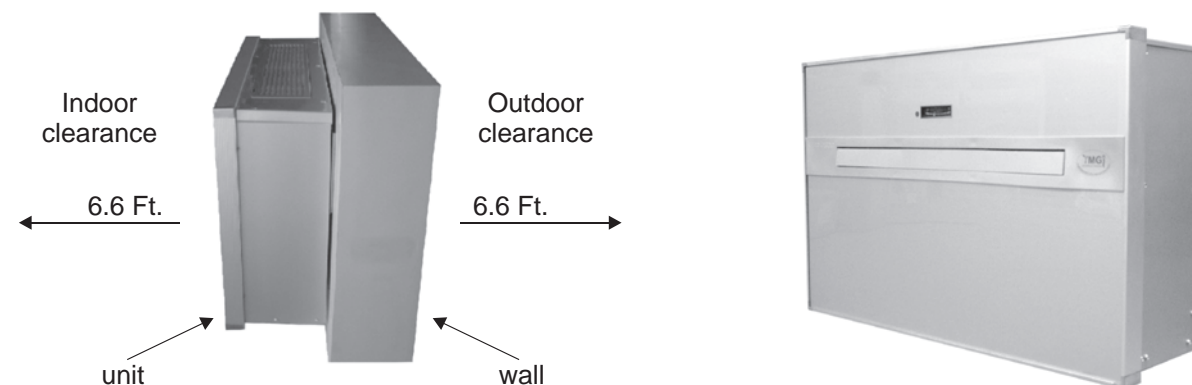

UNIT INSTALLATION

1:1 SCALE PAPER TEMPLATE

Attach the template to the wall following guidelines below.

- * Do not drill any holes until you are completely confident that there are no obstacles in the area you wish to drill and there are no obstructions, which could be hidden by the construction of the wall, for example: electrical wiring water & gas pipes or supporting lintels or beams.
- * Ensure that a spirit level is used, as the air conditioner must be level.
- * Fully follow the installation instructions.

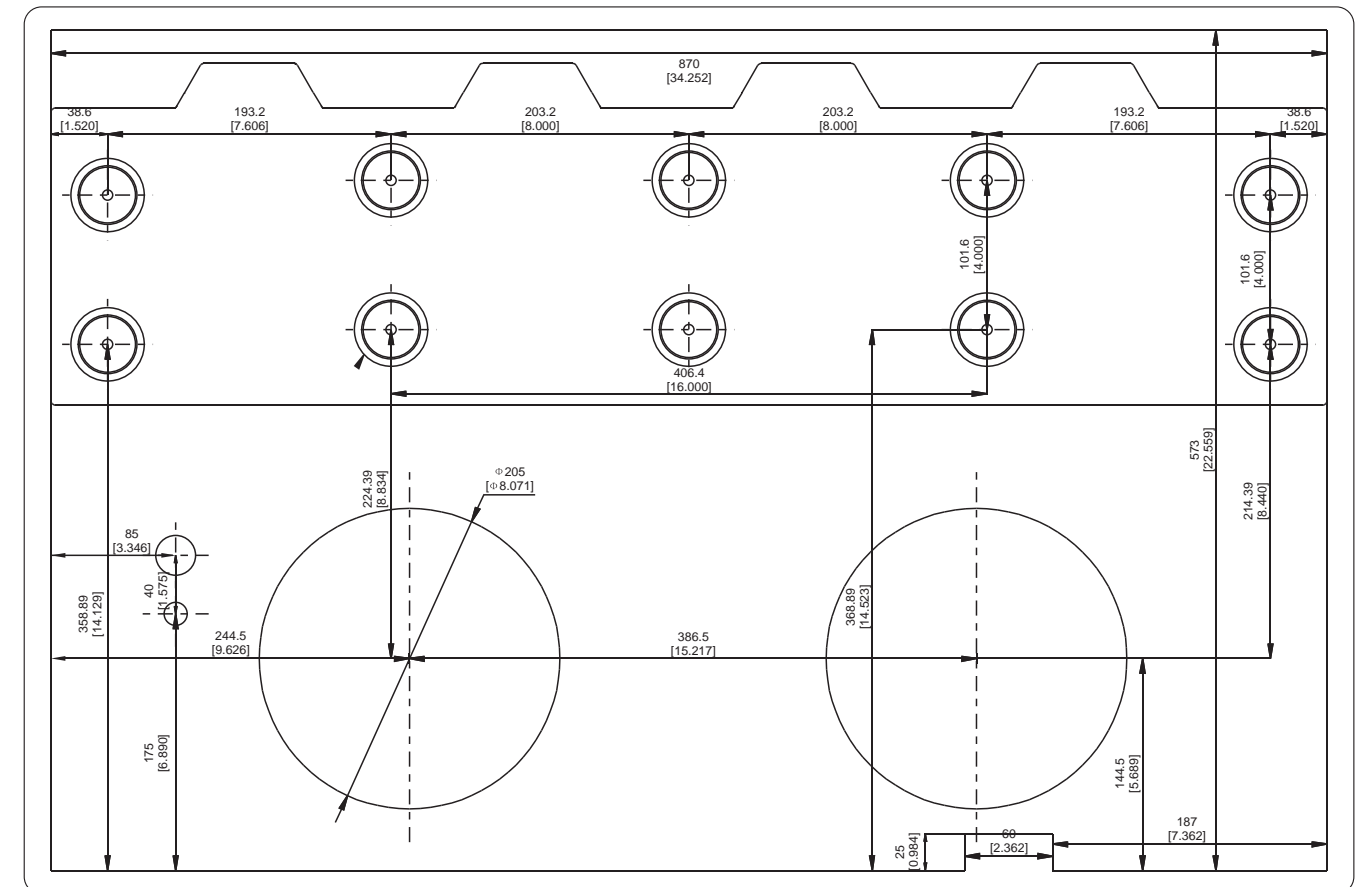

DRILLING THE WALL

Please note: If you are drilling the hole above ground floor level, ensure that an area has been secured and the outside area is supervised while the holes are drilled, until drilling has been completed.

INTAKE AND DISCHARGE AIR HOLES

This operation should be carried out using the proper tools (diamond tip or core borers drills with high twisting torque and adjustable rotation).

Fasten the template to the wall carefully check the distance from the floor and or ceiling and keep it horizontal by using a level.

Use a pilot drill to mark the centre of each core hole to be drilled. Use a core boring head having a diameter of 8" to drill the two holes for intake and discharge air.

It is recommended that the holes must have a slightly downward inclination of 3-5 degrees to prevent any back flow of water from rain at the exterior wall.

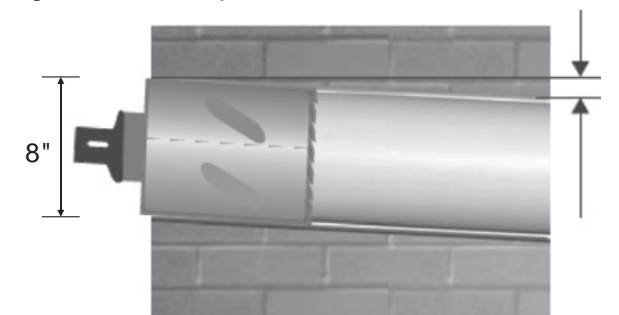

UNIT INSTALLATION

DRAINAGE HOLE

The unit generates condensate that has to be extracted to enable the unit to operate correctly. It is necessary to drill a 1" hole in diameter in the position shown in the paper template. It is for the drain line to go downwards and have a minimum downward inclination of at least 3° along its length.

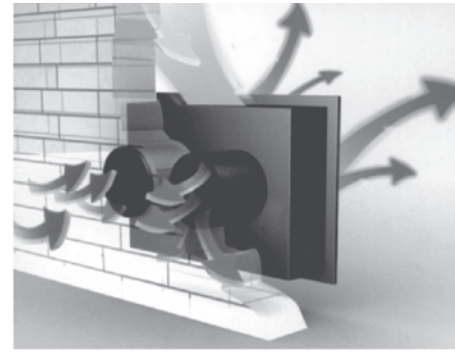

FASTENING THE BRACKET

Once the mounting spot is properly selected, then need to fasten the wall mount bracket onto the wall.

For dry-wall mounting where wall studs are 16" apart: will need to make sure to securely fasten big and long enough screws into the 2 columns of 4 screw holes with 16" center-to-center distance, as illustrated in the picture hereof.

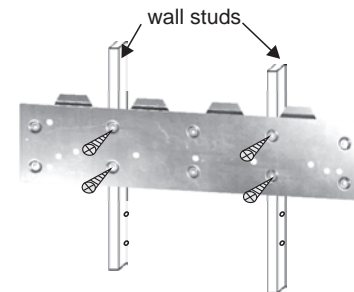

Wall Mount on Dry Wall-Wood Studs

For brick or concrete wall mounting: must securely anchor big and long enough screws into the wall through 4 columns of holes on the mounting bracket.

For other wall mounting: will need to make sure the wall bracket be securely fastened onto sturdy and firm wall, to allow hold 140-150LBs of unit securely.

Suggested tools: stud finder/locator, wood or concrete drilling tools, level, and measuring tape.



Wall Mount On Brick Wall

INSTALLING AIR DUCT & GRILLE

- * Round the 8" wall hole.
- * Trim or extend the air duct to the length needed.
- * Fit the air duct inside the wall against the unit duct connection ports. It is good to put some insulation to avoid possible vibration noise.
- * Fill and seal the gaps.
- * Screw down the grille and fasten it to the wall.



Standard Grille



(Optional Grille-1)



(Optional Grille-2)

Screw down the grille and fasten it to the wall (with the louver towards downwards, to keep from rain splashing into grille/air duct/unit).

UNIT INSTALLATION

HANG THE UNIT INTO THE BRACKET

Lift the unit up by holding the two sides at the bottom but not the front panel.



Tilt the unit slightly towards the wall bracket to feel and try to put the slot hook on the unit into the bracket hang (earing).

The unit is provided with an insulated drainage pipe (24" long), to fit on the sprout that protrudes from the lower rear side of the unit, insert the drainage hole.

The unit then can now be pushed firmly against the wall. Carefully inspect the installation to ensure that the insulating back panel fits firmly against the wall and there are no fissures at the back of the unit.



DRAINAGE

To complete the drainage line, fit the drainage pipe on the drainage hole and push firmly into place (A). A further extension pipe can be added, if necessary.

If the line drains into a vessel (tank or other receiver), this vessel should not be sealed and the drainpipe should not remain immersed in the water.

The drain should flow in a downwards direction, as this is a gravity flow.

Installer must make sure the drain pipe is connected tight while is not kinked or clogged. Must test, by put some water into the DRAIN BASEPAN at the unit bottom (at airflow inlet), to ensure the water can flow out easily, before operating the unit. May need to check from time to time for any possible dirty substances left in the drain pan or drain line. Failure to do so may cause water damage or property damage.

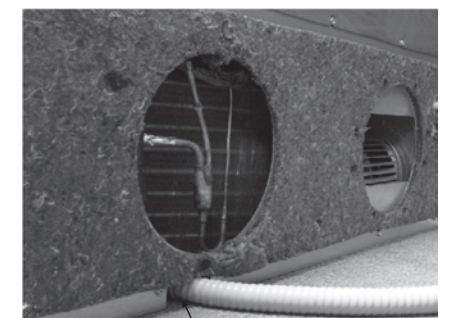

OPERATION

CENTRAL PANEL DIGITAL DISPLAY

The digital display shows the set temperature in degree Fahrenheit or the selected TIMER delay in hour. LED indicator lights in different colours to show the different function as follow:

RED LED power supply is connected;

YELLOW LED timer is on;

GREEN LED compressor is on;

BLUE LED sleep mode is on.

Technical specification see the rating plate or briefs below.

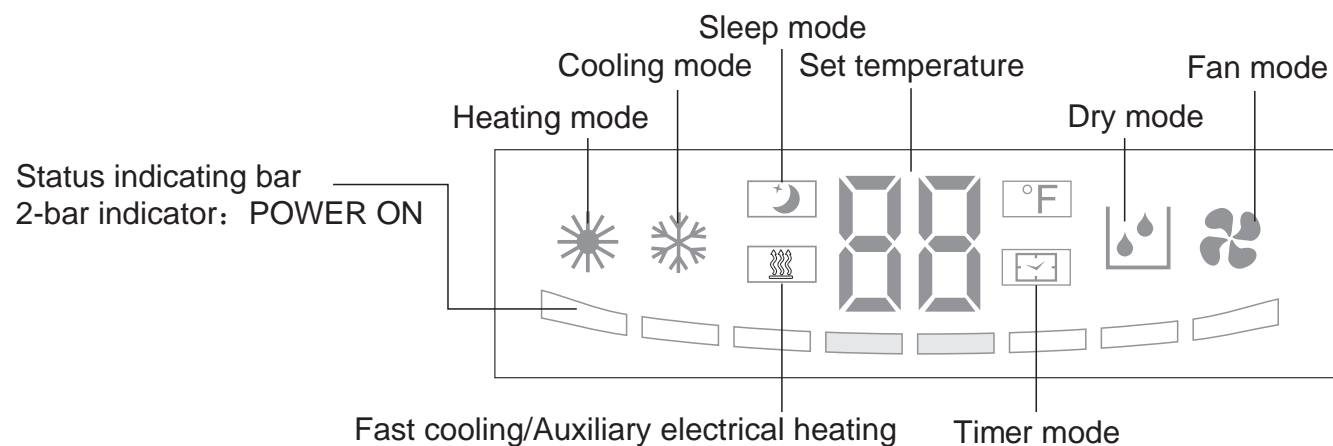
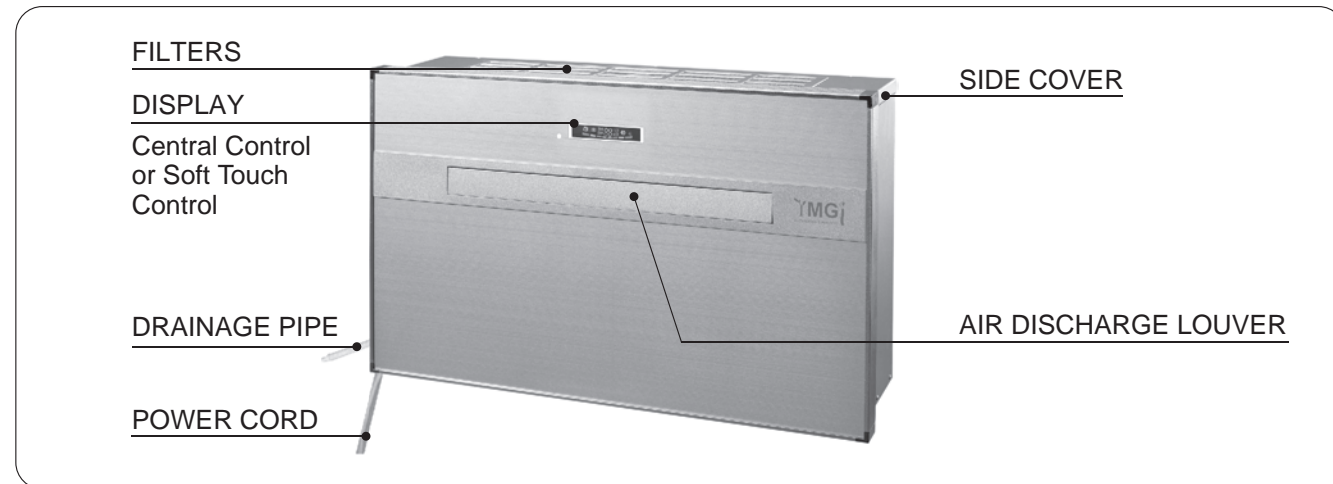

REMOTE CONTROL INDICATIONS

- 1 Auto Function (the temperature will be set at 78°F for cooling, and 68°F for heating)
- 2 Cooling Function
- 3 De-humidifying Function
- 4 Fan Function
- 5 Heating Function
- 6 Temperature Indicator (press 'Up'/'Down' to show the set temperature the temperature range is 64.4°F to 86°F)
- 7 Fan Speed Indicator (Auto, Low, Medium, High)
- 8 Airflow Swing Indicator
- 9 Timer Indicator

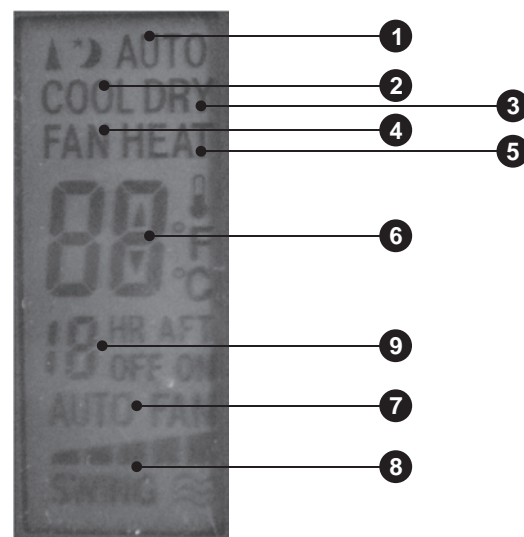

OPERATION

REMOTE CONTROL

The unit should be operated and set using the remote control provided. Each time a button is pressed the unit will sound to confirm the signal has been received.

1. TEMP/TIMER +
2. TEMP/TIMER -
3. DISPLAY
4. ON/OFF
5. MODE
6. FAN
7. SWING
8. OFF
9. ON
10. CANCEL
11. CONFIRM
12. DISPLAY (ON/OFF)
13. SLEEP

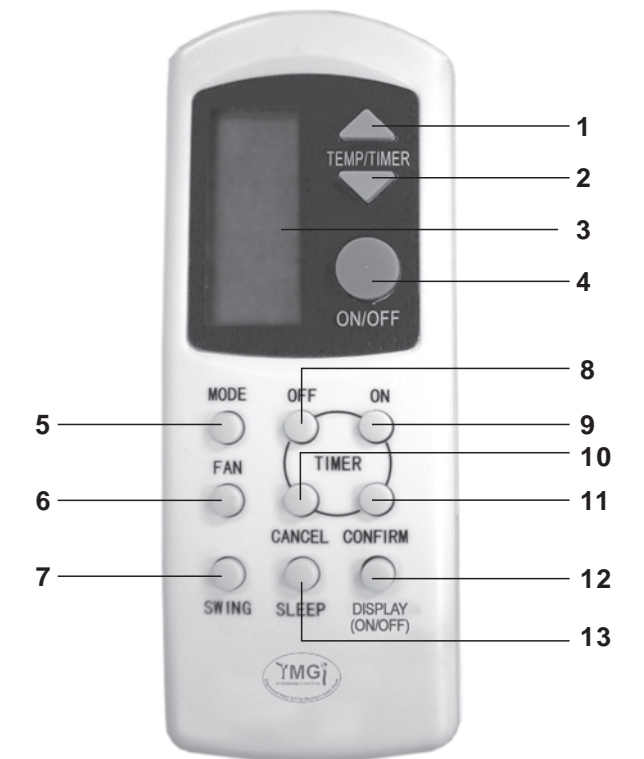

To change the function, press the 'Mode' button (4) repeatedly, until the desired function shows up.

Auto → Cool → Heat → De-humidify

The required room temperature is adjusted using the 'Up' and 'Down' arrows (12&15).

To change the fan speed, press the 'Fan' button (13) one a time, until the desired function shows up.

Auto → HIGH → MEDIUM → LOW

THERMOSTAT CONTROL AND GROUP CONTROL

By replacing with a different thermostat-capable control board, this unit can work with many brands of thermostats that are available in most local stores or contractors (B for heat pump/heating).

By tapping on the features of certain wall mount thermostats (check with thermostat manufacturer's instructions), it is possible to enable group control of any set of WMMS(P) units, with random starting and protection against current surge when many units start at same time.



* The direction of the airflow can be adjusted using the 'Swing' button.

* The timer can be set/cancelled by pressing the 'Timer' button (5).

* The sleep mode can be set/cancelled by pressing the 'Sleep' button (14).

* The current time can be set using the 'Hour' (6) and 'Min' (16) buttons.

* The unit can be switched on or off by using the power 'On/Off' button (8).

NOTE: Please Note When the Required Temperature is less than 64°F or greater than 86°F, 'CONT' will be displayed on the remote control and the unit will operate continuously.

OPERATION

USING THE CONTROLS

A. Power

BATTERY ON/OFF

- Once two AAA batteries are loaded into the remote control battery compartment in the right polarity, LCD screen shows all signs available for 3 seconds before they all go off the screen totally.
- Once one or two batteries are unloaded from the remote control battery compartment, if no button is touched, the LCD screen display will go off in 15 seconds, if any button is pressed within 15 seconds, the LCD screen display will go off right away.

B. Run/Stop "ON/OFF" ON/OFF

- If ON/OFF button is pressed the first time, LCD displays AUTO, temperature meter sign, AUTO FAN and SWING from the top to bottom of the LCD screen;
- If ON/OFF button is pressed after power off, LCD displays what is left prior to POWER OFF (including MODE, TEMPERATURE, FAN SPEED, LOUVER, but excluding SLEEP, TIMER and FRESH).

C. "MODE" MODE

- MODE includes: AUTO, COOL, DRY, FAN and HEAT. Mode changes from one to the next one in a sequence once MODE button is pressed.
 - In AUTO mode, temperature number goes off, all other buttons work.
 - In all other modes, temperature number shows up, all other buttons work.
- Cool only type has not HEAT mode. Each time MODE button is pressed, the operation mode is changed in a sequence: Cool, Dry, Fan only and Heat.

D. Temperature/Time Adjustment "▲▼" TEMP/TIME

- Normally, these buttons are for temperature up and down adjustment at 1F/press, to decrease 1F, press "▼" button once; to increase 1F, press "▲" button once; If held down for continuous adjustment, number changes at 1F/0.5Sec.
- These buttons are for time adjustment too. If pressed intermittently within 5 seconds after pressing TIMER ON or TIMER OFF, time (hour) changes at 1hour/press; if held down continuously, time changes at 1hour/0.5Sec. Time cycle is between 1-12hrs.
- Temperature/Time change will show up on the Control's LCD display.
- Temperature range is 64 to 86F, Time range is 0 to 24Hr or 0 to 12Hr.

E. Fan Speed Adjustment FAN

FAN MODE includes: AUTO, LOW, MED and HIGH. Every time "FAN" button is pressed once, fan sign changes once from one to the next one in a sequence: LOW (1-section/fan blade spins slowly), MED. (3-section/fan blade spins a little quicker), HIGH (5-section/fan blade spins quicker), AUTO (4-blade fan).



F. "DISPLAY (ON/OFF)" DISPLAY

An easy to read LCD display at the indoor unit indicates the operational status and functions of the unit. This display can be turned off, whenever you want, by pressing the "DISPLAY" button on the lower right-hand corner of the remote control. This feature is literally a dream come true, because it allows the room to remain dark at night without the annoyance of the lights. If you wake up during the night, you can also turn the digital display on by pressing the same button and use the display as a night-light and avoid waking your sleeping partner by turning on the regular room lights.

OPERATION

G. SLEEP FUNCTION

Press "SLEEP" button to turn the unit into or out of SLEEP mode. When SLEEP button is pressed, star/moon sign either shows up or goes off. If star/moon sign is ON, MODE turns into SLEEP mode (see related function change separately); if pressed again, star/moon sign goes off, MODE turns into the regular.

This function will increase or decrease the set temperature over time.

The COOL mode SLEEP profile is as follows:

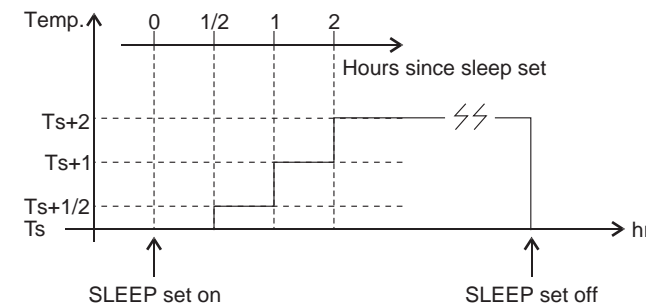

The HEAT mode SLEEP profile is as follows:

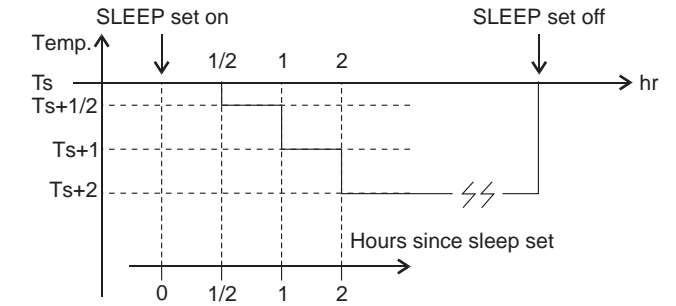

When Sleep Mode Gets Started During Cooling

The set temperature will automatically rise 0.5 or 1 degree, once every 1/2 or 1 hour, for several times, in a period of 2 hours, and then stay at Ts+2 until Sleep Mode button is pressed off, following a sample pattern as illustrated at the left side picture above.

This way, fan blows at low speed, set temperature is getting higher so that the room temperature will not be conditioned too low, to accommodate the decreased cooling load when people fall in sleep at night time, and other heat gain also drops due to less activities and energy consumption and dropped outdoor temperature.

When Sleep Mode Gets Started During Heating

The set temperature will automatically start to drop 1 degree, once every 1/2 or 1 hour, for several times, in a period of 2 hours, and then stay at Ts-3 until Sleep Mode button is pressed off, following a sample pattern as illustrated at the right side picture above.

This way, fan blows at low speed, set temperature is getting lower so that the room temperature will not be conditioned too warm, to accommodate the decreased heating load when people fall in sleep at night time, and other heat loss also drops.

H. SWING (SETTING THE AIRFLOW DIRECTION)

This unit comes with up and down louver swinging feature. It can oscillate between upper limit and lower limit. The horizontal louver will pause for several seconds at its upper limit position to make sure the airflow is delivered to the further spots. It will then stop at any angle in between, whenever the SWING button is pressed during its swinging. When pressed again, it will keep on swinging.

As this smooth airflow is discharged from outlet, this unit is pre-equipped with motorized left-right swinging device. But, the small vertical louvers at the discharge outlet can be adjusted, manually, to the desired position

SETTING THE VERTICAL AIRFLOW DIRECTION

The vertical louvers can be adjusted manually to the desired position

WARNING

* Never move the horizontal louvers manually.

* During cooling/de-humidifying functions, the horizontal louvers should not face downwards for a long time, nor should the vertical louvers be fully turned to the right/left.

DIAGNOSIS CODE & TROUBLE-SHOOTING GUIDELINE

DIAGNOSIS CODE, POSSIBLE CLAUSES, AND SUGGESTED ACTIONS TO USER AND TECHNICIAN:

Codes	Descriptions	Possible Reasons	Suggestion to User	Technician Trouble-Shooting
E1	Condensate Full in drain pan	Dain pan dirty, drain hose clogging, water level switch failure, loose connection, bad control board/ components, etc.	Check if drain hose is clogged; if not, need to call your installing or service technician.	<ol style="list-style-type: none"> 1) Shut off power; 2) Follow possible clauses listed at the left, to check one by one; 3) To save time for quick diagnosis as much as possible, suggest your technician to make appointment with YMGI tech. support, and call us while the technician is at job site. 4) Better to check the unit, get problems and model model #, and serial # ready, before calling YMGI tech. support. 5) Need the technician physically, at the job site, use right tools and experience, to find all the clauses and correct or fix the problems and not to leave any bugs.
E2	Indoor air temp. sensor failure	Bad temperature sensor; loose connection, damaged wires, bad control board/ components, etc.	Lift up grille/cover, to check if the sensor looks bad or drops out of holding socket/ pocket; or, to call installing or service technician.	
E3	Indoor coil copper tube sensor failure	Bad temperature sensor; loose connection, damaged wires, bad control board/ components, etc.		
E4	Abnormal cooling	Dirty filters/coils, refrigerant leaks over time, pipe too long, kinks or clogging in pipe line or valves, pipe damage, sensor failure, compressor or board or other component failures, etc.	<ol style="list-style-type: none"> 1) Regularly check and clean indoor unit filters, indoor and outdoor coils. 2) The service valves at outdoor unit should be generally cool at cooling mode; hot at heating mode; 3) Call your installing or service technician to check unit. 	
E5	Abnormal heating			
E6	Cooling-outdoor coil low temp. protection	Outdoor too cold to run cooling mode, windy, too much refrigerant, short piping, etc.		<ol style="list-style-type: none"> 1) Check if these are caused by installation or component failure; 2) There could be nothing abnormal, but the unit is at protection mode, which means the current ambient temperature is not proper to run the unit; 3) If there is something wrong, need to find all the clauses and correct or fix the problems and not to leave any bugs.
E7	Cooling-Indoor coil anti-freeze protection	Dirty filter/coils, indoor fan motor failure, loose blower wheel/motor connection, too much or less refrigerant, pipe/cap. tube/valve clogging, etc.	<ol style="list-style-type: none"> 1) Shut off the unit; 2) Cooling, wait until weather allows the unit to re-start, or switch to alternative cooling equipment which allows lower ambient cooling; 	
E8	Heating-outdoor coil high temp. protection	Outdoor temperature too warm to run heating mode, too much refrigerant, short piping, etc.	<ol style="list-style-type: none"> 3) Heating, wait until weather allows the unit to re-start, or switch to base-board heater, gas furnace or other alternative heating sources during cold hours/days. 	
E9	Heating-indoor coil anti-to hot protection	Dirty filter/coils, indoor fan motor failure, loose blower wheel/motor connection, too much refrigerant, pipe/cap. tube/valve clogging, etc.		
E0	Heating-outdoor coil too cold protection	Outdoor temperature is too cold to run heat pump/ heating.		

WARRANTY AND TECH. SUPPORT

YMGI warrants to the purchaser/owner(s) that YMGI products be free from defects in material and workmanship under the normal use and maintenance, with the standard Limited Product Warranty Policies that comes with the unit or sales package.

YMGI IS NOT RESPONSIBLE FOR

- * Damage or repairs required as a consequence Customer do-it-yourself(DIY) installation and/or any other faulty installation or improper application.
- * Damage or repairs needed as a consequence of any misapplication, abuse, improper servicing, unauthorized alteration, or improper operation.
- * Damage as a result of floods, winds, fires, lightning, accidents, corrosive atmosphere, or other conditions beyond the control of YMGI.
- * Any damages to person or property of whatever kind, direct or indirect, special or consequential, whether resulting from use or loss of use of the product.
- * Failure to start due to voltage conditions, blown fuses, open circuit breakers, or other damages due to the inadequacy or interruption of electrical service.
- * Parts not supplied or designated by YMGI.
- * Products installed outside USA or Canada.
- * Regular equipment maintenance or field service or field inspection.
- * Any problems due to improper cooling and heating load calculation of the room/building the air conditioner/heat pump system is to be installed. Equipment users can get the calculation schedule from your room/building architect or your installation or related service HVAC contractor, who should have knowledge and tools to do these calculation correctly.
- * Any problems due to improper sizing and selecting air conditioner/heat pump system. These equipment sizing and selection work should be conducted by either your room/building architect or your installation or related service HVAC contractor, who should have knowledge and tools to do these calculation correctly, and get your approval, before your purchasing these air conditioner or heat pump equipment.
- * Any problems due to improper installing of the air conditioner/heat pump system. Installation should be conducted by currently licensed HVAC technician, following manufacturer installation instructions, all governing safety codes, with care and professionalism.
- * Any problems due to improper operation of the air conditioner/heat pump system. Users shall keep the manual and look up in the manuals for the correct understanding how the unit will work and how to operate the unit correctly.
- * Any problems due to improper maintenance of the air conditioner/heat pump system. Like a car, regular maintenance or yearly checking is necessary for the unit to work properly for you, before the season comes. For example, air filter shall be checked for cleanliness from time to time. Remote control batteries shall be checked for enough power, before judging the unit is not working...

CONTACT FOR FIELD SERVICE OR REPAIR

The following people, in a prioritized sequence, will take care of your request or issue:

- 1) The original installer; otherwise,
- 2) Your current service contractor; otherwise,
- 3) Authorized contractor in YMGI list that is close to you; otherwise,
- 4) Authorized Distributor in YMGI Distributor list; otherwise,
- 5) Contractor/Distributor you prefer who is close to you.

CONTACT FOR GENERAL TECHNICAL QUESTIONS OR SUPPORT, IN A SEQUENCE:

- 1) The original installer; otherwise,
- 2) The current service contractor; otherwise,
The original licensed installer or current service contractor should be contacted first of all, since they installed the unit and/or know more details than anybody else.
They will check the unit and find out the problems with the professional knowledge about HVAC and electric product installation by using special tools or instrument.
They can contact YMGI technical support for technical help during unit installation or inspection.
Product model and serial numbers needed, which can be found on unit nameplate sticker, so that our technician can quickly identify the unit, parts and wiring diagrams, among our many products and models.
- 3) The distributor; where the unit is purchased from otherwise,
- 4) YMGI Technical Support:
Tel: (866) 833-3138*703 Email: techsp@ymgigroup.com



