



YMGi Group

POB 1559

O'Fallon, MO 63366, USA

Tel: (866)833-3138 Fax: (866)377-3355

Web Site: www.ymgigroup.com

Email: info@ymgigroup.com

Literature Part No: LIT-WMMS-(56)-DC IVTR-USER MANUAL-20131130
Subject to Continuous Engineering Change and Product Improvement without Notice.

YMGi is the Trademark and Property of YMGi Group. Copyright of YMGi Group.



YMGi, Engineered Comfort Products for A Sustainable and Efficient Green World !

INSTALLATION INSTRUCTION AND OPERATION MANUAL

DC INVERTER R410A - SERIES 56

MINI SPLIT WALL MOUNT - SOLAR BOOSTED

(PV TYPE)

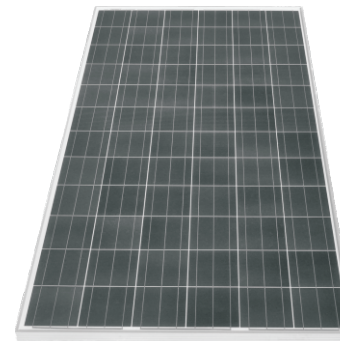
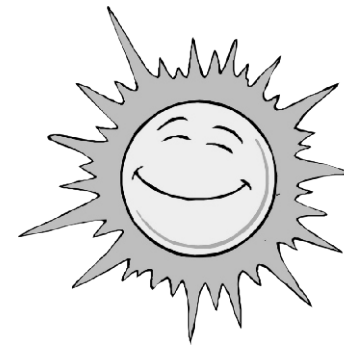

⚠ WARNING

This product is designed and manufactured free from defects in material and workmanship for normal use and maintenance. Installation, operation, maintenance and service shall follow professional practices for regular cooling and heating equipment, NEC, State, City or Local Codes and related manuals from YMGi. Otherwise, damage to equipment or property and even injury to people may occur.

Installer: Currently licensed HVAC technician only. Read manual before installation. Fully fill in warranty registration card.

User: Keep this manual for future maintenance and service use.

Service: Use this manual for service reference.



LITERATURE: LIT-WMMS-(56)-DC IVTR-USER MANUAL-20131130

CONTENTS

WELCOME AND PLEASE READ THROUGH MANUALS	2
INSTALLING TECHNICIAN/CONTRACTOR'S JOBS AND RESPONSIBILITIES	4
LIMITED PRODUCT WARRANTY POLICIES	5
LIMITED PRODUCT WARRANTY REGISTRATION CARD	6
WARRANTY AND TECHNICAL SUPPORT	7
IMPORTANT NOTES	8
NOTICES FOR OPERATION	9
NOTICES FOR USE	11
INSTALLATION SERVICE-NOTICES FOR INSTALLATION	12
NOTICES FOR INSTALLATION	12
RECOMMENDED TOOLS FOR INSTALLATION	13
INSTALLATION ILLUSTRATION	14
INSTALLATION DIMENSION DIAGRAM	15
INSTALL INDOOR UNIT	16
INSTALL PV-MODULE	18
CHECK AFTER INSTALLATION AND TEST OPERATION	23
INSTALLATION AND MAINTENANCE OF HEALTHY FILTER	23
REMOTE CONTROL-BUTTON NAME & FUNCTIONS	24
OPERATION OF REMOTE CONTROL	27
EMERGENCY OPERATION	28
CLEAN AND CARE	29
TROUBLE SHOOTING	30
CUSTOMER AND TECHNICIAN MUST READ	32
USER NOTES AND INSTALLATION/SERVICE/MAINTENANCE NOTES	38

⚠ CAUTION All Units Shall Be Installed by Experienced or Licensed Contractor Or Technician. Read Manuals before Installation.

⚠ CAUTION Following NEC, State and Local Codes and Installation Instructions of All Units, Otherwise Unit Warranty Will Be Void and Serious Damage To People Or Property May Be Caused.

⚠ WARNING YMGI Group Will NOT Take Any Responsibilities for Any Damage or Loss Due to Do-It-Yourself(DIY) self-installation and other Improper Installation or Operation or Natural Disaster.

⚠ WARNING Don't Supply Power until All Wiring and Tubing and Checking is Completed. Ground the Unit Following Instructions and NEC, State and Local Codes.

⚠ DANGER Connect All Wiring Securely. Loose Wire or Other Bad Contact May Cause Arc or Overheating and Fire Hazard.

WELCOME AND PLEASE READ THROUGH MANUALS

Dear Customer(s)/End User(s)/Unit Purchaser(s)/Installer(s)/Contractor(s):

Thanks for choosing YMGI products.

The YMGI equipment you purchased is either a split-type or a self-contained cooling/heating system which requires an installer's license, certification, knowledge, experience, carefulness and details for a successful and good installation. This equipment is different from those window or portable air conditioners you can normally purchase from local retail stores such as Home Depot, Lowe's, Sears, etc. which the manufacturer may not require licensed personnel to install.

Reading and following the YMGI Group's recommendations, suggestions, and requirements, written in the following pages and other documents, is the first step to ensuring a smooth and trouble free installation & proper operation of your products for many years to come.

The quality of the installation plays a key role in whether the units will work well and for an extended period of time. The information we provide in our manuals is for the sole purpose of reminding you and your installer.

It is our ultimate goal to help insure that your YMGI units are installed properly and correctly from the very beginning to the very end. This ensures that your YMGI units will work well and not only provide a comfortable room but also peace of mind.

⚠ WARNING

YMGI doesn't recommend nor allow any do-it-yourself (DIY) installation (partially or fully), since DIY will cause problems sooner or later to your units and your upfront saving is Not saving down the road.

YMGI warranty doesn't cover any DIY units.

If you have any questions about your unit or even doubt if the unit has any problem, you can first check against the manuals. If you can not find answers, then you can contact your local installer or service technician to physically inspect the unit. If at the time of inspection the installer or service technician have any questions they can contact YMGI technical support division directly at:

Toll Free Number: (866)833-3138

Email: techsp@ymgigroup.com

IMPORTANT NOTE-YMGI HOLDS FINAL EXPLANATION:

YMGI Group, POB 1559, O'Fallon, MO 63366 is the only party who holds the final explanation (in authorized writing) about any descriptions or data in YMGI-published materials, including but not limited to YMGI product brochures, manuals, pamphlets, catalogs, videos and any other media. YMGI's distributors, installers, dealers, agents, customers or any other third parties shall not supersede YMGI to make any explanation about what YMGI-published materials mean. Any uncertainty or questions, arising from YMGI distributors, installers, dealers, agents, customers or any other third parties, should be passed directly to YMGI for an explanation in writing.

⚠ ATTENTIONS

1. Be sure to hire only one certified, licensed HVAC Company to complete 100% of the installation so that all details of the installation are clear, complete and well taken care of.
2. Be sure to have ONLY the licensed HVAC professional perform all parts of the installation. Factory Warranty will be lost if any portion of the installation is not performed by licensed HVAC contractor. DIY or partial DIY will void ALL factory warranties. One example of partial DIY would be calling the HVAC technician to release refrigerant or the sort while other installation has or is to be conducted by non-HVAC technician.
3. With hiring a technician that is offering their services as a "side job" and not through their licensed HVAC company may pose a possible risk of an incomplete or unsatisfactory installation of no guaranteed workmanship and lack of further service, if needed.
4. Have the installing technician read in full the installation manual of the product model you have. Some details may vary and some may be the key to determine the success and quality of the installation. Experience with certain manufacturer may not be applied fully to another manufacturer. For example, wiring, refrigerant adjustment and trial testing procedures may differ from manufacturer to manufacturer and model to model. Any ignoring or negligence may cause unit failure or damage which could be irrevocable and permanent.
5. All of YMGI's products are fully tested and have passed rigorous safety and performance standards and others related to the industry, before being packed and shipped. YMGI only uses famous brands as suppliers for their parts that are also known for their high quality and performance. The quality of the installation plays a key role as much as up to 90% importance in your unit's overall performance and lifetime. A poor installation can result in unit failure and inefficiency either immediately or over a period of time.
6. Some licensed contractor/technician may make a mistake some time. YMGI doesn't supervise nor is able to control their installation. It is key that the installer take each variable into account during the initial installation in order to ensure a complete and professional installation and properly working units.

⚠ WARNING

The following will cause damage to the unit and key components and the loss of your unit's factory warranty:

1. Any foreign substances introduced into the system as a result of failure of not sealing the ends of the refrigeration piping before pulling through structures at time of installation.
2. Not installing an oil P-trap in the suction copper line where indoor unit is located 18' or more below outdoor unit.
3. Cross piping and/or cross wiring on any units including more than one single zone or a multi zone system.
4. Not conducting a positive leak check by charging the system with dry-nitrogen and soap bubble testing.
5. Not conducting a negative leak check by evacuating the copper lines for 30 minutes. Vacuum must be held at 500 micron or better for at least 5 minutes, starting from 5 minutes after the vacuum pump is shut off.
6. Not conducting a positive leak check prior to the negative leak check.
7. Not selecting the correct size of wire or circuit breaker.
8. Not answering ALL questions in the technician's checklist inside the warranty registration form.

⚠ WARNING

The following may be overlooked, ignored, or treated as not a problem during your installer's installation, but actually will cause your unit to underperform or even cause unit failure.

1. Any kinks or improper bending of the copper piping.
2. Any improper flaring or not centering of the flare with the nut, or not tightening any connection.
3. Not trial testing each indoor unit individually.
4. Not reading technical data (temp/time/pressure/current) after the system is stabilized (normally compressor needs to work at least 10 minutes). Data read too early may lead to inaccurate or false judgment or even a false sense of security.

In an effort to protect our customers from any possible faulty installation which can lead to premature unit failure, we like to provide the above information to you in addition to the technician. You can judge yourself and observe while your system is being installed, though your observation may not be treated as any guarantee whether your system would be installed properly and professionally. If at any time you feel there may be an installation issue, please have your technician contact YMGI at (866)833-3138 x 703 to clear your questions.

- 1) Check with the customers to find out detailed information of structure to be conditioned, local weather (typical design and extreme temperature/humidity conditions, cooling and heating hours), previous and existing HVAC equipment, usage and dependence on the new HVAC equipment or the YMGI products.
- 2) Performing a cooling/heating load calculation by using commercially available professional programs/methods such as Right-J (Manual J) for residential HVAC applications/jobs and Right-CommLoad (ASHRAE RTS/CLTD) for light commercial and commercial HVAC applications/jobs.
- 3) Check with YMGI distributor/sales or contact manufacturer directly to obtain information to fully understand YMGI products, including but not limited to product features, cooling/heating performance-at standard ratings/conditions and extreme conditions, allowed indoor and outdoor temperature/humidity ranges, installation, operation, maintenance, service, warranty, parts and so on.
- 4) Properly select correct (most suitable) YMGI product models (of units and accessories) for your HVAC applications/jobs and list them in your proposal/quote, in writing, on your company's quote form or letter head, basing upon the information you get from 1), 2) and 3) above.
- 5) List your currently valid HVAC license # and EPA # in your proposal/quote.
- 6) Make sure you are the only party to perform the whole installation job and you will not sub-contract any part of the installation to any non-licensed parties/persons. You will be solely responsible for the full installation that you have been contracted for.
- 7) Check to make sure you have all the materials you need to properly and correctly finish the installation. The YMGI units and accessories may be just a portion of what you need. YMGI employees and YMGI distributors/sales, dealers and agents are not installers and may only be able to provide suggestions to you, but you are the only sole decision maker to determine what other materials you must need and/or the customer may want to fulfill the installation job.
- 8) Check against both NEC and your local codes to make sure all the installation of YMGI units and accessories meet these requirements.
- 9) Connect the unit to correct electrical power source. In the area where lightning or storm incurs frequently, a proper type/size of power surge protector needs to be installed between the outdoor unit and power source.
- 10) Select proper types and sizes of HVAC circuit breakers, disconnect switch boxes, wires and conduits from circuit breaker to disconnect box and then from disconnect box to outdoor unit.
- 11) Select proper location to mount indoor units and outdoor units with all factory requirements being followed (cooling/heating/air is not blocked or restricted, mounting structure is secure, aesthetical looking, installation convenience is considered, maintenance/service clearance is ensured and all applicable codes are met and etc.).
- 12) Cap/tape the two ends of every copper line before running them through structures to keep from any foreign substances entering into pipe and causing contamination. Label them A-A, B-B, C-C, D-D, or other marks on each pair of copper line/wiring cable set to keep from any possible cross-piping or cross-wiring in multiple zone installations or where pipes for different single zone systems are close to one another.
- 13) Secure the wiring cables that connect between indoor unit and outdoor unit, following applicable NEC and local codes for your particular installation. If there is no special NEC or local code to govern how these wires are to be installed, you can tape/cable tie them along with insulated copper line.
- 14) Tighten all pipe and wire connections to keep from any possible leakage or false connection.
- 15) Conduct positive pressure leakage checking of inter-connecting copper lines between each indoor unit and outdoor unit by charging dry-nitrogen at outdoor unit service port (note: don't back-seat stopping valve, at this time). Liquid soap solution shall be applied at all pipe connections to check for leakage. A 1/4-5/16" hose/valve adaptor may be needed if you have traditional manifold of 1/4" connection hose.
- 16) If there is no positive leaking, then conduct negative pressure leakage checking of inter-connecting copper lines between each indoor unit and outdoor unit by pulling vacuum at outdoor unit service port (note: don't back-seat stopping valve, at this time) and checking if the vacuum level 500 Micron can be held for at least 20 minutes.
- 17) If there is no leakage found at refrigeration pipe connections, flip up the indoor unit face panel and remove filter, carefully pour some clear water onto the up-right aluminum coil surface to test if the water can drain out of each indoor unit freely without any leakage being found.
- 18) If there is water leakage found, locate the source of the leak and correct. Only after everything is clear engage the correct electrical power to the system.
- 19) Then back-seat stopping valves of outdoor unit to release refrigerant from outdoor unit into inter-connecting pipes and indoor unit.
- 20) Check to make sure both indoor unit and outdoor unit are powered on correctly before controlling the indoor unit to operate in fan mode first. Then move on to test cooling, dehumidifying/drying, heating and other modes.
- 21) Read refrigerant pressures and pipe/valve temperatures only until the system is stabilized (normally 10 minutes after cooling/heating mode is started successfully). Put this data into the technician checklist in the lower half section of the Limited Product Warranty Registration Card/Form.
- 22) Adjust refrigerant charging level (remove refrigerant if pipe is shorter/temperature is colder; add refrigerant if pipe is longer/temperature is warmer), following manufacturer's instructions, if average pipe length is shorter or longer than 25' and pressure/temperature readings at outdoor unit service valves are not falling into normal ranges.
- 23) Explain to the user/owner(s) about proper unit operation and maintenance and leave your contact information for them to reach you easily.
- 24) If the customer finds the unit doesn't work properly and cannot resolve the issue themselves, check the customer's units/parts/accessories and correct the problem if there is any. Communicate with YMGI-technical support line (866)833-3138 x 703, if needing help.

Following these requirements will aid in ensuring the units to be installed to the general HVAC practicing standards and necessary factory requirements, finding any possible problems early, preventing any further damage to the unit and helping ensure a properly working unit over its lifetime.

LIMITED PRODUCT WARRANTY POLICIES

The YMGI products are designed and manufactured free from defects in workmanship, and materials for normal use. However, for any reason, including many handlings and occasions between the YMGI factories/warehouses and where you receive the products, the unit doesn't work, YMGI Group will help to remedy the occurrence in the following warranting ways:

Compressor: YMGI will warrant the compressor of YMGI-validated and approved warranty filing, for a period of 5 years from the date of successful installation at original location.

Parts: YMGI will warrant parts of YMGI-validated and approved warranty filing, for one year from the date of successful installation at original location.

All warranty compressors and parts replaced will become the sole property of YMGI Group and must be returned to YMGI Group upon request. Warranty parts may be new or refurbished. All parts are tested and approved before shipping.

At no time does the YMGI Group warrant labor cost of any type. Warranty will start from the date of successful installation at initial location, or 90 days as of original shipping date from YMGI Group, whichever comes first.

This is a standard warranty of limited liability and DOES NOT cover the following:

- * Any damage or repairs to properties, or persons as an incident or consequence of improper or faulty transportation, installation, operation, maintenance or service.
- * Damage caused by frozen or broken water hoses or refrigeration pipes in the event of equipment failure.
- * Any damage as a result of floods, fire, wind, lightening, accidents, corrosive atmosphere or any other conditions beyond the control of YMGI Group.
- * Any damage due to interruption or inadequate electrical service to equipment.
- * Any products that are installed outside the US or Canada.
- * Any unit that has been moved from the original installation address.
- * Any labor costs associated with the installation or service of the unit.
- * Poor unit performance due to improper unit selection (SEER, Unit size).

To validate the above warranties, ALL the following conditions must all be fulfilled:

1. The unit was fully (100%) and successfully installed by licensed or certified HVAC technicians.
2. The unit was installed following all NEC, state and local codes.
3. The unit was installed following all instructions and manuals made by YMGI Group.
4. ALL fields, especially the technician-checklist, of the **Limited Warranty Registration Card/Form** were filled completely by the installing technician and signed by both the installing company technician and the unit owner.
5. The **Limited Warranty Registration Card/Form** and a copy of the original installing company's invoice had been received by YMGI Group-Warranty Dept., POB 1559, O'Fallon, MO 63366, within 7 days of successful installation.

No warranty filing will be validated or approved, if any one of the above 5 conditions is not met.

Product registration doesn't guarantee the validity of this limited warranty statement.

Steps to follow for warranty part replacement:

1. Installing or service technician contacts YMGI tech support at 1-866-833-3138 ext 703 from the jobsite, to double-check and confirm with YMGI Technical support the exact part(s) needed to fix all the problems.
2. YMGI will check the customer's warranty filing. Parts for validated and approved warranty will not be charged. Parts of invalid warranty filing or unapproved warranty requesting, will be charged accordingly.
3. YMGI will ground ship out the parts ASAP. Expedited shipping is available at the customer's cost.
4. Replacement parts of approved warranty registration are to be warranted for the remainder of the 1 year parts and 5 year compressor warranty. Purchasing of replacement parts of invalid warranty filing or unapproved warranty requesting, will be as they are and bear no warranty.

YMGI keeps on improving products with various engineering changes without prior notice. Such improvements or changes include but not limited to product specification, appearance, functions, sizes, packaging and others. These improvements or changes will not void the limited warranty stated herein. YMGI keeps the final explanation of this warranty policy.



LIMITED PRODUCT WARRANTY REGISTRATION CARD



YMGI GROUP
Innovative, Competitive, Efficient & Convenient

LIMITED PRODUCT WARRANTY REGISTRATION CARD / FORM

YMGI to Fill Top Portion, at Shipping, and Keep Copy A; Center Copy B for Installer to Fill and Mail back to YMGI; Bottom Copy C for Customer to Fill and Keep

For YMGI Use Only	The Company the Unit Was Sold Through: _____	Shipping Packing List Number: _____	Registration Card Serial No. _____	
	Did the Company Pay to YMGI: _____	HVAC Contractor/Technician--Name _____	Date the Filled Registration Card YMGI Received: _____	
	Installation Invoice Attached to the Registration Card _____	Hired YMGI-Recommended HVAC Contractor/Technician? _____	Unit(s) Work Successfully (Yes/No): _____	Warranty Approved _____

Outdoor Serial Number (One Outdoor Unit, One Registration Card/Form): _____	Indoor Serial Number: _____	For Multi Zone Units _____	Unit #1 _____	Unit #5 _____
			Unit #2 _____	Unit #6 _____
			Unit #3 _____	Unit #7 _____
			Unit #4 _____	Unit #8 _____

Contact Where the Units are Installed:

Name: _____ Phone: _____ Fax: _____

Address: _____ Email: _____

City: _____ State (Province): _____ Country: _____

Contact of the Installing HVAC Contractor/Technician:	YMGI-Recommended Contractor/Technician:
Technician Full Name (Print): _____	Phone/Fax: _____
HVAC Technician's Company Name: _____	Email: _____
Address: _____	City:State (Province): _____
Currently Licensed or Certified HVAC Technician License or Certification Number: _____	License Approved or Certified by: _____
Official Phone # to Check the License Validity: _____	

List for Installing HVAC Technician to Double Check Installation Quality, and Warranty Processing Purpose (if not filled by technician, or not filled fully, warranty will void)

- 1) Are you the only one to install whole system? If not, % of installation done by you (HVAC technician).
- 2) What had been done, prior to your arrival?
- 3) Did you read the User Manual and Installation Instruction, before you started the installation?
- 4) Who unpacked the unit and accessory boxes to check for damage?
- 5) Supply electrical power V/Ph/Hz measured at wiring terminal block of indoor unit: _____ outdoor unit: _____
- 6) Incoming electrical power V/Ph/Hz measured at terminal blocks of indoor unit: _____ outdoor unit: _____
- 7) Wire gauge, length and terminal colors between circuit breaker/disconnect switch to outdoor unit: _____
- 8) Wire gauge, length and terminal colors between each indoor and outdoor unit: Unit A _____ Unit B _____ Unit C _____ Unit D...
- 9) The size of HVAC circuit breaker/fuse or disconnect switch to the outdoor unit: _____
- 10) Are the inter-connecting wires and copper lines between indoor and outdoor units installed/covered/protected by line set covers, or anything else?
- 11) What is the refrigerant pipe length between each indoor unit and the outdoor unit? Unit A _____ Unit B _____ Unit C _____ Unit D...
- 12) Where is/are the indoor unit(s) located? Unit A _____ Unit B _____ Unit C _____ Unit D...
- 13) What is the elevation difference between each indoor unit and the outdoor unit? Unit A _____ Unit B _____ Unit C _____ Unit D... (indoor unit above outdoor unit +, below -)
- 14) Did you check the indoor unit for condensate leakage and refrigerant leakage, before and after connecting them?
- 15) Where is the outdoor unit located? Is the outdoor unit anchored to Ground wall balcony roof other ground or secured onto wall location or pad bracket?
- 16) Have you checked to make sure there is no cross-piping and no cross-wiring between any two indoor units (zones)? How did you do it, who was with you?
- 17) Were the refrigerant pipe ends capped or taped seal, prior to running them through structures to keep debris from entering the copper lines?
- 18) Have you checked and run cooling or heating, one unit by one unit, all working fine?
- 19) Did you charge the inter-connection copper pipes and indoor unit with nitrogen to check for positive leakage (pressures 150-200PSI), before conducting vacuuming leakage check?
- 20) Did you vacuum correctly to check the connecting pipes and indoor unit for leakage, what was the micron gauge reading, for how many minutes?
- 21) Did you check if the compressor can be started and stopped in a correct (design) manner?
- 22) If copper length were not made to the supplied or recommended refrigerant pipe length, how much refrigerant added or deducted?
- 23) Measured refrigerant pressures at outdoor service suction valve, when unit was st. Heat pump (PSI): _____ Cooling (PSI): _____ Outdoor Ambient Temp. (°F): _____
- 24) What were the measured temperatures (probe not touching any metal): At cooling: indoor return air °F, discharge air °F, and outdoor °F At heating: indoor return air °F, discharge air °F, and outdoor °F
- 25) Have you checked all unit functions, with customer's witness, and all functions are correct?
- 26) Did you show the user how to operate the unit? Did he/she understand you?
- 27) Do you provide regular one-year free technical service for this installation?
- 28) Do you list the working details in the invoice and leave a copy to the customer?

Installation Finished and Unit Works Successfully. Print Name of Installation HVAC Technician: Signature: _____	Installation Finished and Unit Works Successfully. Print Name of Owner: Signature: _____
Date and time: _____	Date and time: _____

By signing above, I acknowledge the liability and responsibility for any false statement or not telling all the facts, and I authorize YMGI to check the details of the filled above, and make its decision on warranty. I understand our filing or filling the warranty card/form DOESNT mean automatic warranty approval, because warranty is approved only to those qualified and successful installations by qualified HVAC technician. I know the warranty, if approved, is a standard 5-year compressor and 1-year other parts only, without any labor coverage. I agree to and will follow all the contents contained in the Limited Product Warranty Policy that YMGI, not other entity, stated in public, including but not limited to manuals, web site, email, etc.

Important Note: A copy of the installing HVAC company's invoice to show all their work details, your payment proof, center copy B of this registration card filled after a successful installation, all three (3) MUST be mailed together to Warranty Dept., **YMGI Group, POB 1559, O'Fallon, MO 63366**, for warranty processing. Customer keeps bottom copy C. YMGI will check against copy A that was kept at YMGI.



WARRANTY AND TECHNICAL SUPPORT

YMGI warrants to the purchaser/owner(s) that YMGI products be free from defects in material and workmanship under the normal use and maintenance, with the standard Limited Product Warranty Policies that comes with the unit or sales package.

YMGI IS NOT RESPONSIBLE FOR

- * Damage or repairs required as a consequence Customer do-it-yourself(DIY) installation and/or any other faulty installation or improper application.
- * Damage or repairs needed as a consequence of any misapplication, abuse, improper servicing, unauthorized alteration, or improper operation.
- * Damage as a result of floods, winds, fires, lightening, accidents, corrosive atmosphere, or other conditions beyond the control of YMGI.
- * Any damages to person or property of whatever kind, direct or indirect, special or consequential, whether resulting from use or loss of use of the product.
- * Failure to start due to voltage conditions, blown fuses, open circuit breakers, or other damages due to the inadequacy or interruption of electrical service.
- * Parts not supplied or designated by YMGI.
- * Products installed outside USA or Canada.
- * Regular equipment maintenance or field service or field inspection.
- * Any problems due to improper cooling and heating load calculation of the room/building the air conditioner/heat pump system is to be installed. Equipment users can get the calculation schedule from your room/building architect or your installation or related service HVAC contractor, who should have the knowledge and the tools to do these calculations correctly.
- * Any problems due to improper sizing and selecting air conditioner/heat pump system. These equipment sizing and selection work should be conducted by either your room/building architect or your installation or related service HVAC contractor, who should have the knowledge and the tools to do these calculations correctly, and get your approval, before purchasing the air conditioner or heat pump equipment.
- * Any problems due to improper installing of the air conditioner/heat pump system. Installation should be conducted by currently licensed HVAC technician, following manufacturer installation instructions, all governing safety codes, with care and professionalism.
- * Any problems due to improper operation of the air conditioner/heat pump system. Users shall keep the manual and refer to it for the correct understanding of how the unit will work and how to operate the unit correctly.
- * Any problems due to improper maintenance of the air conditioner/heat pump system. Like a car, regular maintenance or yearly checking is necessary for the unit to work properly for you, before the season comes. For example, air filter shall be checked for cleanliness from time to time. Remote control batteries shall be checked for enough power, before judging the unit is not working...

CONTACT FOR FIELD SERVICE OR REPAIR

The following people, in a prioritized sequence, will take care of your request or issue:

- 1) The original installer; otherwise,
- 2) Your current service contractor; otherwise,
- 3) Authorized contractor in YMGI list that is close to you; otherwise,
- 4) Authorized Distributor in YMGI Distributor list; otherwise,
- 5) Contractor/Distributor you prefer who is close to you.



CONTACT FOR GENERAL TECHNICAL QUESTIONS OR SUPPORT, IN A SEQUENCE:



- 1) The original installer; otherwise,
- 2) The current service contractor; otherwise,
The original licensed installer or current service contractor should be contacted first of all, since they installed the unit and/or know more details than anybody else.
They will check the unit and find out the problems with the professional knowledge about HVAC and electric product installation by using special tools or instrument.
They can contact YMGI technical support for technical help during unit installation or inspection.
Product model and serial numbers needed, which can be found on unit nameplate sticker, so that our technician can quickly identify the unit, parts and wiring diagrams, among our many products and models.
- 3) The distributor; where the unit is purchased from otherwise,
- 4) YMGI Technical Support:
Tel: (866) 833-3138*703 Email: techsp@ymgigroup.com

IMPORTANT NOTES

SAFETY WARNINGS

READ THESE SAFETY WARNINGS COMPLETELY PRIOR TO ANY USE

	Ground connection
	Disconnect the plug

	Forbidden
	Imperative

These precautions are essential and must be strictly observed.

DO NOT draw on the power cord or refrigeration lines. Install them in secured positions. Plastic cover of line set is recommended.

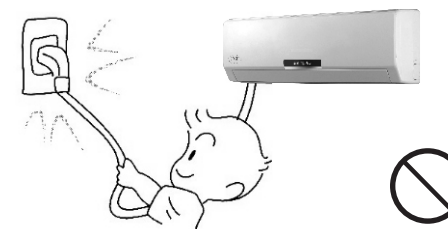

DO NOT use smaller than enough wires. Do not put several circuits to one breaker. Don't use smaller than enough circuit breakers. Otherwise power failure or fire may be caused.

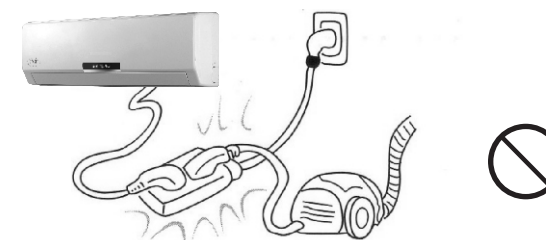

DO NOT pull on the power cord or refrigeration lines. Install them in a secured position. A line set plastic cover is recommended.

DO NOT install the unit in places where there is exposure to flammable materials or gas leakage.

DO NOT use wire or circuit breakers that do not meet electrical safety standards. Several circuits cannot be connected to one breaker.

DO NOT wire or open the unit while it is running. Make sure to shut off all circuits prior to inspecting or servicing the unit.

DO NOT install unit in a damp laundry room or near flammable gas. All units must be protected by certified electrical circuit breakers and in accordance with all safety codes.

DO NOT use the unit in cool or dry mode for prolonged periods where humidity is higher than 80%.

DO NOT blow the cold air directly towards people for prolonged period. Otherwise, people may get cold.



DO NOT wire or open unit while unit is running. Sparks or fire may occur. It may cause a shock to people.

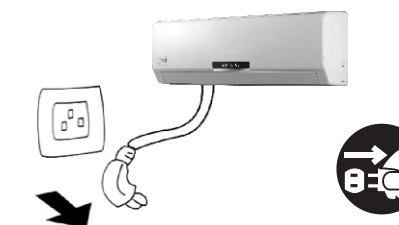

DO NOT install the indoor unit close to cooking surfaces or ventilation systems. Poor placement could inhibit peak performance.

DO NOT blow cold air directly towards people for extended periods.



DO NOT use chemical solvents, flammable insecticides, or abrasive materials. Clean the unit only with a soft dry cloth or rag.

DO NOT continue to operate the unit if there is any abnormal odor, burning, scorching, or smoke. Stop and disconnect the unit immediately.

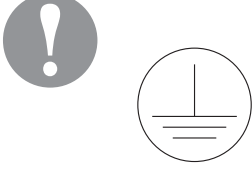
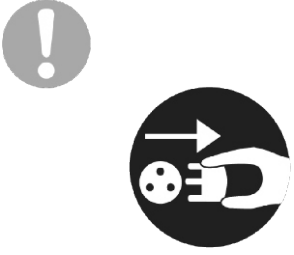

DO NOT use the system for anything other than what it was designed for or any non-HVAC purposes. Do not store near food, paint, or other chemicals.

DO NOT operate the unit for prolonged periods without refreshing ambient air. Opening a door or window periodically will suffice.

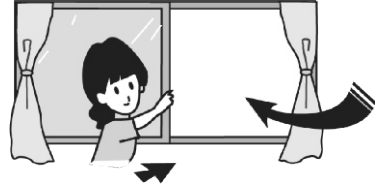
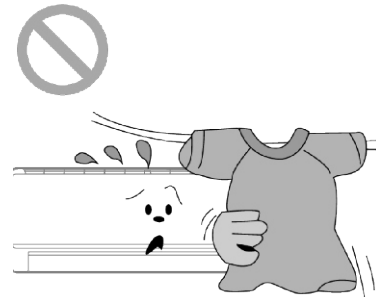
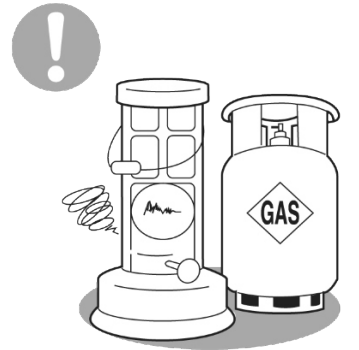
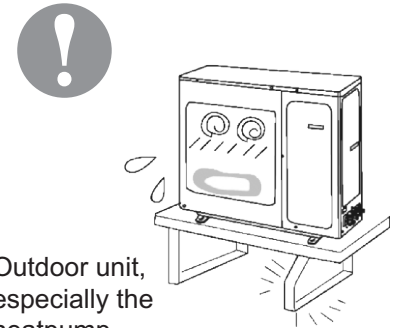
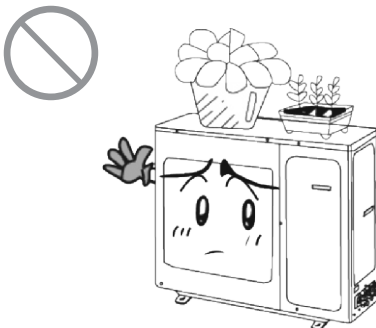
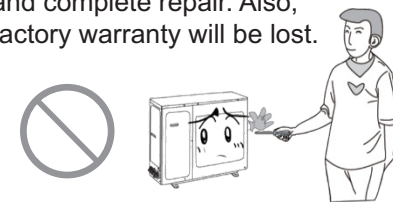
NOTICES FOR OPERATION

<p>The unit must be securely grounded.</p> <p>The cable shall be connected to the grounding device in the home or building.</p> 	<p>* Be sure to pull out the power plug when not using the air conditioner for a long time.</p>  <p>Otherwise, the accumulated dust may cause fire or electric shock.</p>	<p>Select the most appropriate temperature.</p> 
<p>Don't leave windows and doors open for a long time while operating the unit.</p> 	<p>Don't block the air intake or outlet vents of both the outdoor and indoor units.</p> 	<p>Keep combustable substances away from the units more than enough distance.</p> 
<p>Mounting bracket must be sturdy and secured.</p>  <p>Outdoor unit, especially the heatpump outdoor unit, must be installed at least 3-5 inches above the ground, to keep from possible ice being built up in cold weather.</p>	<p>Don't step onto the top of unit. Don't place anything atop of it.</p> 	<p>Don't attempt to install or repair the unit by yourself. Saving on these work is not worthy, since you miss chance to have the professional look into the unit for a full diagnosis and complete repair. Also, factory warranty will be lost.</p>  <p>Handy man may successfully conduct some work. But, it is about responsibility and liability. Customer will have to take responsibility and liability for the DIY installation or or repair.</p>

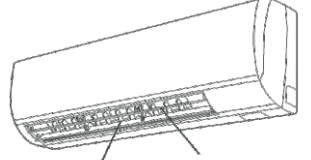
NOTICES FOR OPERATION

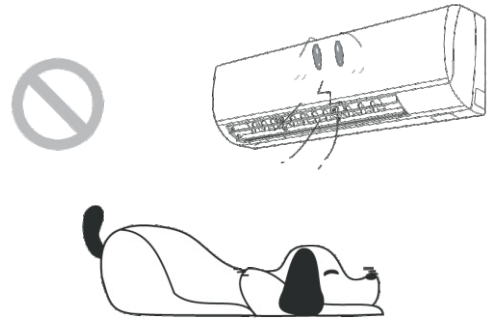
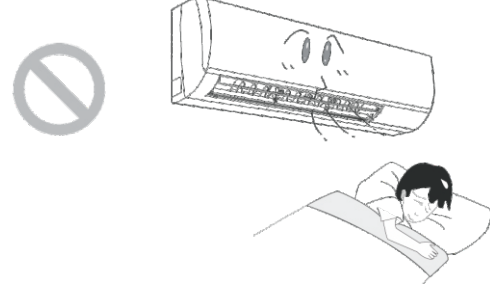
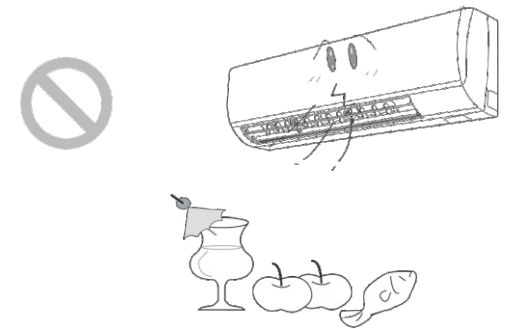
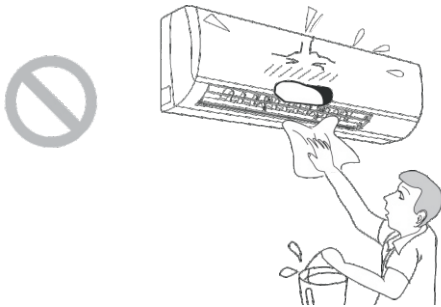
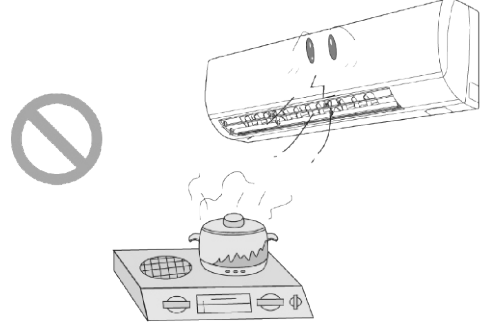
<p>Must not cut off or damage power cables and control wires.</p> <p>In case of any damage found on wires, must replace with good one without any delay.</p> 	<p>* The airflow direction can be adjusted appropriately, by adjusting the louvers of upward/downward and left and right accordingly.</p>  <p>Louver of left/right direction Louver of upward/downward direction.</p>
<p>* Don't insert hands or other foreign substances into the air intake or outlet vents.</p>  <p>Otherwise it will cause accident.</p>	<p>* Don't blow the conditioned air towards animals and plants directly.</p> 
<p>* Don't blow the cold wind to the body for a long time.</p>  <p>It can cause the health problems.</p>	<p>* Don't use the unit to dry clothes, preserven foods, etc.</p> 
<p>* Splashing water on the air conditioner can cause an electric shock and malfunction.</p> 	<p>* Don't place a space heater near the unit.</p> 

NOTICES FOR USE

WORKING PRINCIPLE AND SPECIAL FUNCTIONS FOR COOLING

Principle:

Air conditioner absorbs heat in the room and transmit to outdoor and discharged, so that indoor ambient temperature decreased, its cooling capacity will increase or decrease by outdoor ambient temperature.

Anti-freezing function:

If the unit is running in COOL mode and in low temperature, there will be frost formed on the heat exchanger, when indoor heat exchanger temperature decreased below 32°F the indoor unit microcomputer will stop compressor running and protect the unit.

WORKING PRINCIPLE AND SPECIAL FUNCTIONS FOR HEATING

Principle:

* Air conditioner absorbs heat in the room and transmit to outdoor and discharged, will increase, its heating capacity will decrease by outdoor ambient temperature. so that indoor ambient temperature increased, so room heating capacity.

* If outdoor temperature got lower, please operate with the other heating ventilating equipments.

Defrosting:

* When outdoor temperature is low but high humidity, after a long while running, frost will form on outdoor unit, that will effect the heating effect, at this time, the auto defrosting function will act, the heat running will stop for 8-10mins.

* During the auto defrosting, the fan motors of indoor unit and outdoor unit will stop.

* During the defrosting, the indoor indicator flashes, the outdoor unit may emit vapour. This is due to the defrosting, it isn't malfunction.

* After defrosting finished, the heating will recover automatically.

ANTI-COOL WIND FUNCTION

In "Heat" mode, under the following three kinds of state, if indoor heat exchanger doesn't arrive at certain temp., indoor fan will not act, in order to prevent cool wind blowing(within 2 mins):

1. Heating starts. 2.After Auto Defrost finished. 3.Heating under the low temperature.

Introduction of DC solar power management

The out-door unit can handle DC solar power input besides AC power input. If the solar power device (poly-crystalline solar panel for instance) were connected to out-door unit, the unit would preferentially consume the solar power. And the AC power would be synchronously consumed as complement. The rated voltage of DC solar power should be less than 165V and the rated current should be less than 9A.

Working temperature range		
	Indoor side DB/WB(°F)	Outdoor side DB/WB(°F)
Maximum cooling	95/75	118/86
Minimum cooling	70/59	70/-
Maximum heating	75/---	70/60
Minimum heating	68/---	5/-

The operating temperature range (outdoor temperature) for cooling unit is 70°F~ 118°F; for cooling and heating unit is 5°F~ 118°F.

INSTALLATION SERVICE-NOTICES FOR INSTALLATION

! IMPORTANT NOTICES

- 1) The unit installation work must be done by qualified personnel according to the local rules and this manual.
- 2) If the air conditioner has not plug, directly connect it into the fixed circuit, a breaker should be installed in the fixed circuit. all pole of this breaker should be switching off and the distance of the contact should be at least 0.12".

INSTALLATION SERVICE-NOTICES FOR INSTALLATION

BASIC REQUIREMENTS FOR INSTALLATION POSITION

Install in the following place may cause malfunction. If it is unavoidable contact with service center please:

- * Place where strong heat sources, vapors, flammable gas or volatile objects are emitted.
- * Place where high-frequency waves are generated by radio equipment, welders and medical equipment.
- * Place where a lot of salinities such as coast exists.
- * Place where the oil (machine oil) is contained in the air.
- * Place where a sulfured gas such as the hot spring zones is generated.
- * Other place with special circumstance.

INDOOR UNIT INSTALLATION POSITION SELECTION

- 1) The air inlet and outlet vent should be far from the obstruction, make sure that the air can be blown through the whole room.
- 2) Select a position where the condensing water can be easily drained out, and the place is easily connected for outdoor unit.
- 3) Select a location where the children can not reach.
- 4) Can select the place where is strong enough to withstand the full weight and vibration of the unit. And will not increase the noise.
- 5) Be sure to leave enough space to allow access for routine maintenance. The height of the installed location should be 98.43 in or more from the floor.
- 6) Select a place about 1m or more away from TVset or any other electric appliances.
- 7) Select a place where the filter can be easily taken out.
- 8) Make sure that the indoor unit installation should accord with installation dimension diagram requirements.

NOTICES FOR INSTALLATION

SAFETY REQUIREMENTS FOR ELECTRIC APPLIANCES

- 1) The power supply should be used the rated voltage and AC exclusive circuit, the power cable diameter should be satisfied.
- 2) Don't drag the power cable emphatically.
- 3) It should be reliably earthed, and it should be connected to the special earth device, the installation work should be operated by the professional. The air switch must have the functions of magnetic tripping and heat tripping, in order to protect the short circuit and overloading.
- 4) The min. distance from the unit and combustive surface is 59 in.

EARTHING REQUIREMENTS

- 1) Air conditioner is type electric appliance, thus please do conduct reliable earthing measure.
- 2) The yellow-green two-color wire in air conditioner is earthing wire and cannot be used for other propose. It cannot be cut off and be fix it by screw, otherwise it would cause electric shock.
- 3) The earth resistance should accord to the National Criterion.
- 4) The user power must offer the reliable earthing terminal. Please don't connect the earthing wire with the following place:
 - * Tap water pipe
 - * Gas pipe
 - * Contamination pipe
 - * Other places that professional personnel consider them unreliable.

OTHERS

- 1) The connection method of unit and power cable as well as the interconnect method of each isolated component should refer to the circuit diagram stick on the unit.
- 2) The model of the blown fuse and rated value should refer to the silk-screen on the controller or fuse sleeve.
- 3) The appliance shall be installed in accordance with national wiring regulations.
- 4) This appliance is not intended for use by persons (including children) with reduced physical, sensory or mental capabilities, or lack of experience and knowledge, unless they have been given supervision or instruction concerning use of the appliance by a person responsible for their safety.
- 5) Children should be supervised to ensure that they do not play with the appliance.

RECOMMENDED TOOLS FOR INSTALLATION



1) Mounting Indoor & Outdoor Units and Running Piping/Wiring

Ruler (Not Shown)
 Stud-Finder
 Dry-Wall Saw
 Electric Drill
 3" Hole Saw
 Drill Extension
 Hammer Drill and Bit (Not Shown)
 Measuring Tape
 Level
 Flash Light
 Screw Driver (Phillips and Flat)
 Hammer
 Knife
 Scissors
 Goggled Glass
 Mask
 Gloves
 Ladder

2) Refrigeration Related Work

Individual Wrench Set (Use Two at One Time)
 Flare-Nut Tool Set (Not Shown)
 Hex Head Allen Wrench Sets (Metric and Imperial)
 Brazing Rods and Brazing Torch
 Outfit for AC Application (Not Shown)
 Brazing Flux
 Nitrogen Cylinder for Positive Pressure Leakage Check (Not Shown)
 Soap Bubble for Positive Pressure Leakage Check (Not Shown)
 Vacuum Pump for Negative Pressure Leakage Check
 Helium Refrigerant Minor Leakage Check (Not Shown)
 Manifold

3) Electrical Related Installation

Wire Cutter
 Wire Stripper
 Sharp Plier
 Cable Ties
 Black Tape for Electrical Use
 Electrical Meter

4) Trial Running Units and Inspection

Clamp Meter (Not Shown)
 Manifold
 Infra Thermometer (Not Shown)

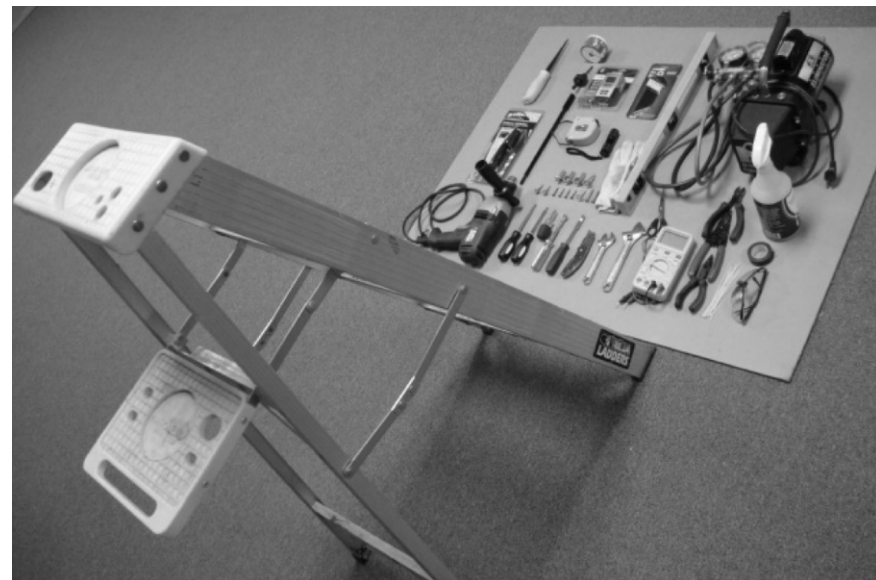

INSTALLATION ILLUSTRATION

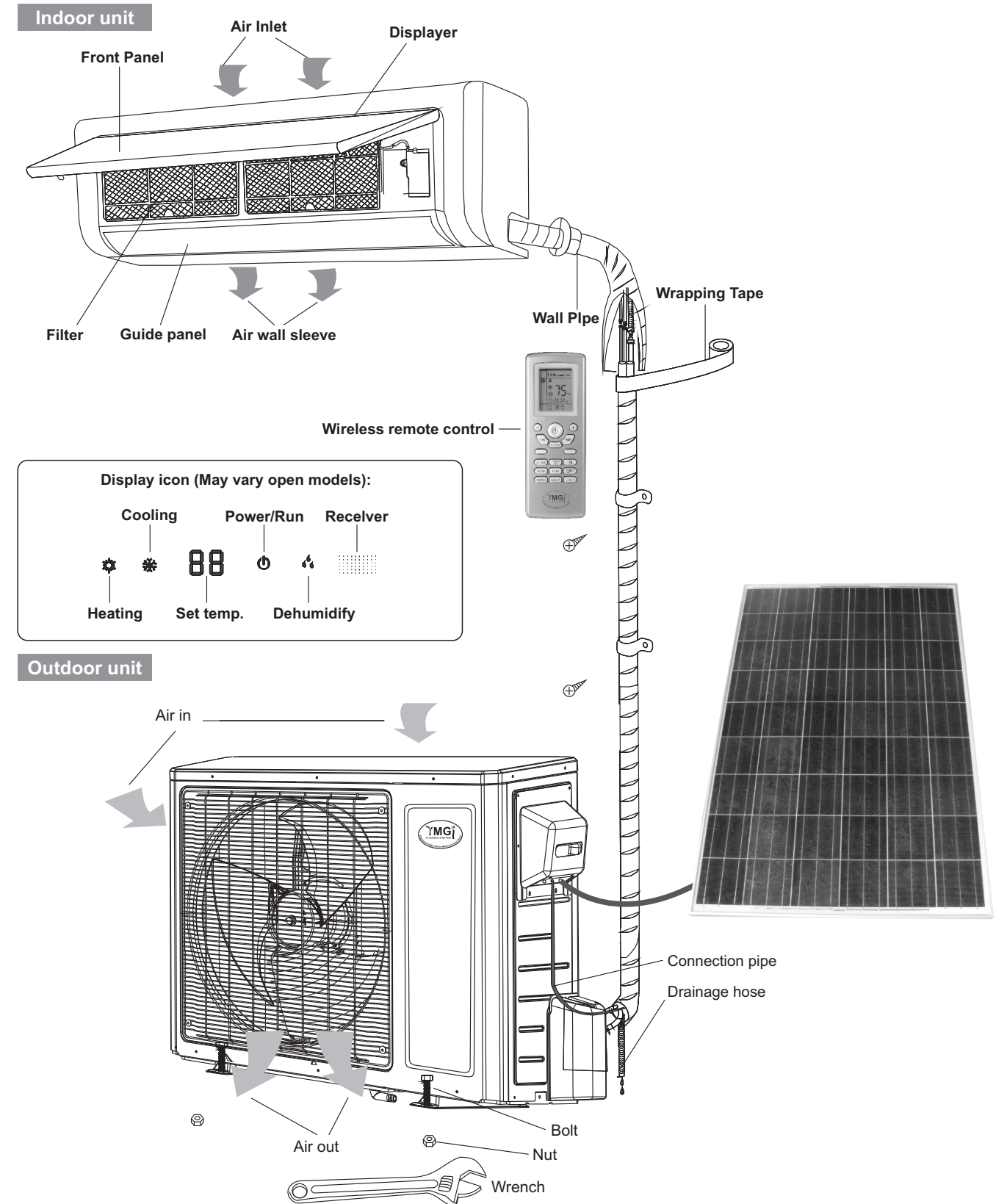

Notes: Actual unit/ part looking and installation may vary from the illustrated. Subject to continuous improvement and change without prior notice.

INSTALLATION DIMENSION DIAGRAM

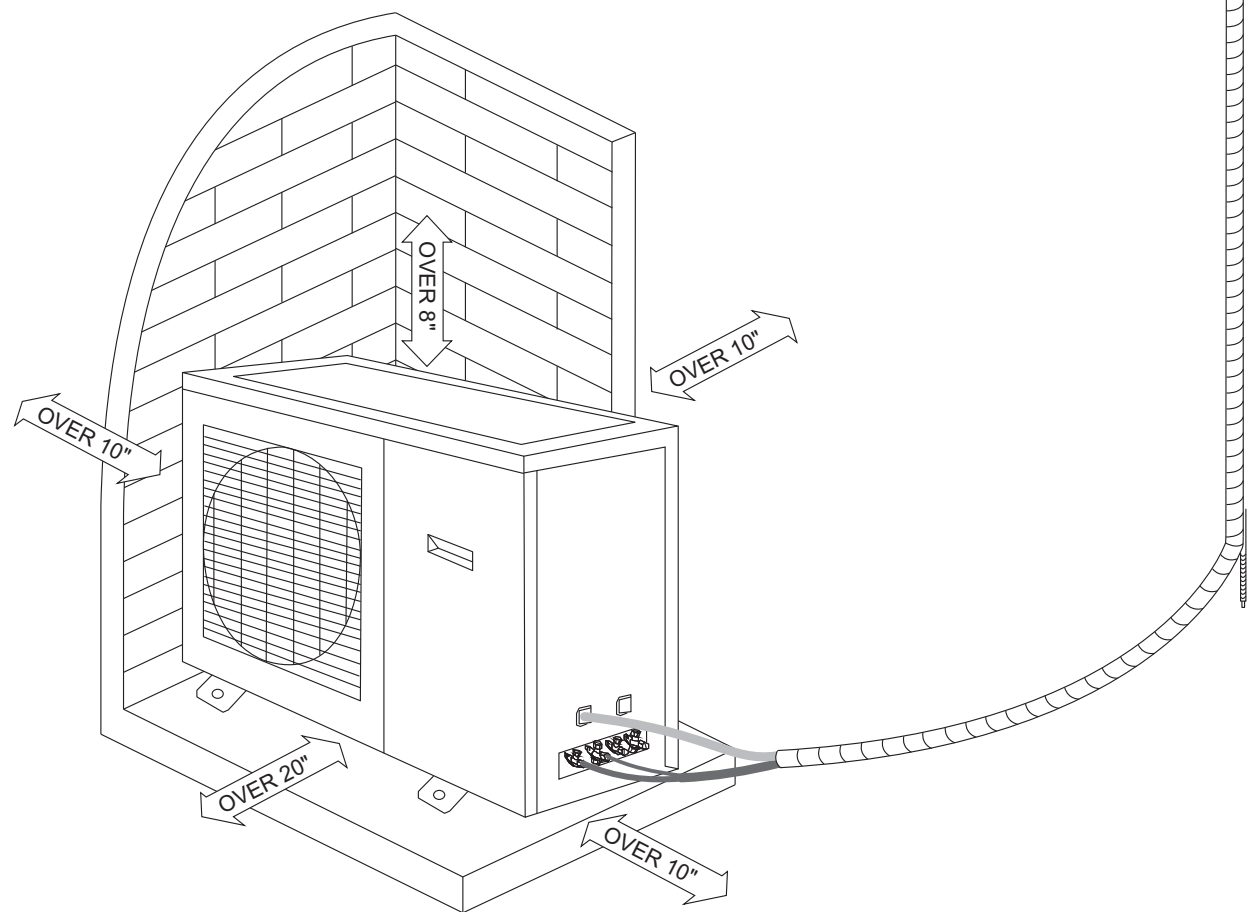
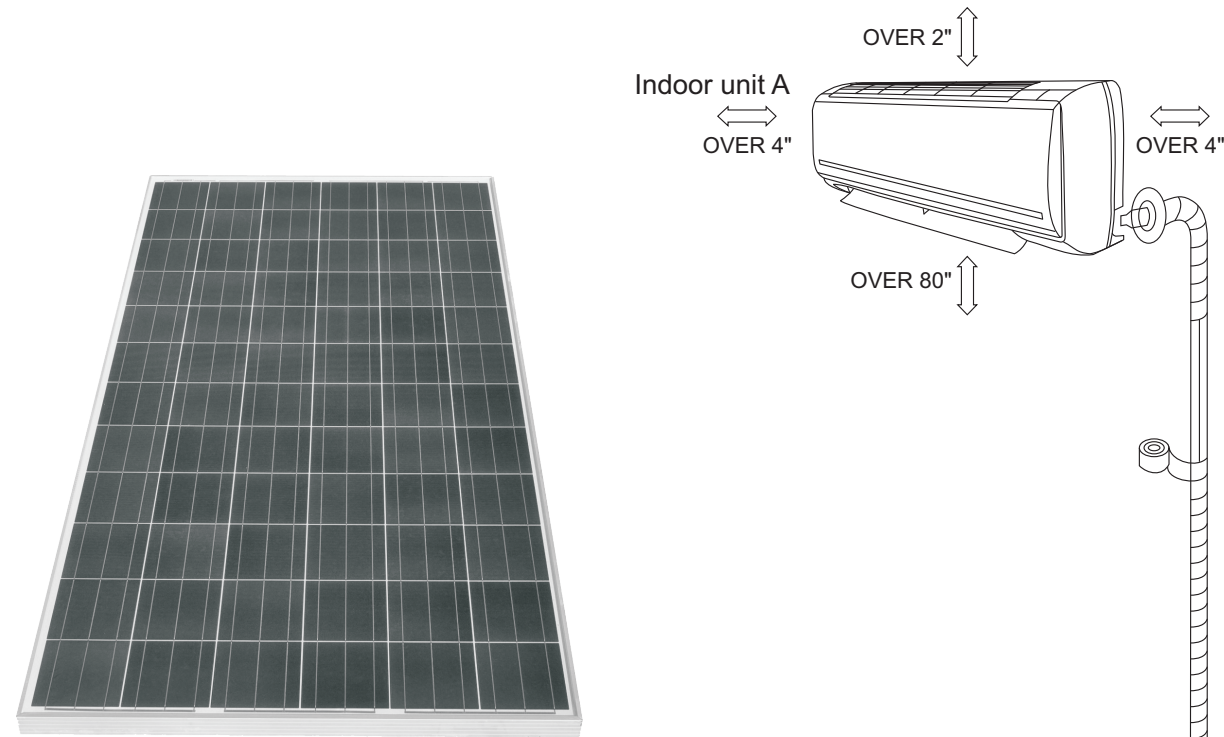

INSTALL INDOOR UNIT

INSTALL THE REAR PANEL

- 1) Always mount the rear panel horizontally. Due to the water tray of indoor unit has been adopted the both-way drainage design, the outlet of water tray should be adjusted slightly down when installing, that is taking the outlet of the water tray as the center of a circle, the included angle between the evaporator and level should be 0 or more, that is good for condensing water drainage.
- 2) Fix the rear panel on the wall with screws. (Where is pre-covered with plastic granula)
- 3) Be sure that the rear panel has been fixed firmly enough to withstand the weight of an adult of 60kg, further more, the weight should be evenly shared by each screw.

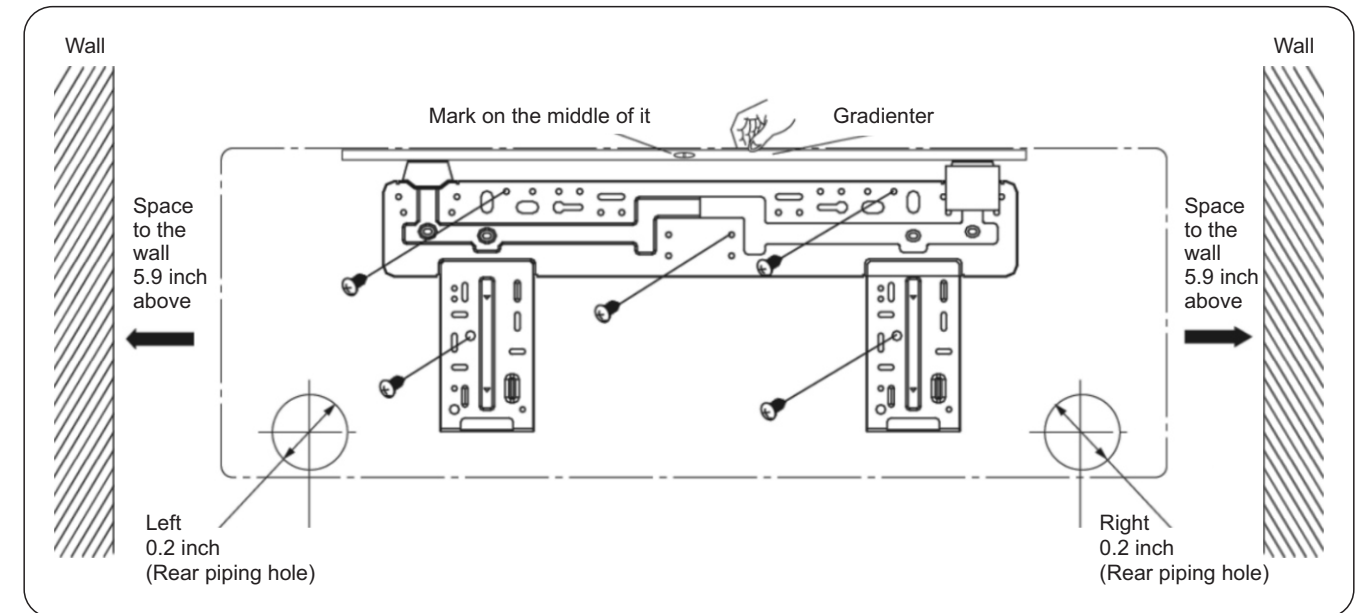

INSTALL THE PIPING HOLE

- 1) Make the piping hole (U55) in the wall at a slight downward slant to the outdoor side.
- 2) Insert the piping-hole sleeve into the hole to prevent the connection piping and wiring from being damaged when passing through the hole.

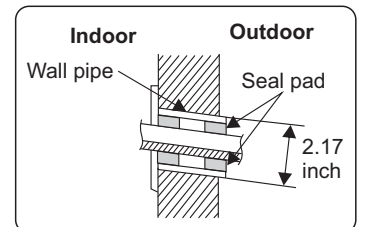

INSTALL THE WATER DRAINAGE PIPE

- 1) For well draining, the drain hose should be placed at a downward slant.
- 2) Do not wrench or bend the drain hose or flood its end by water.
- 3) When the long drainage hose passing through indoor, should wrap the insulation materials.

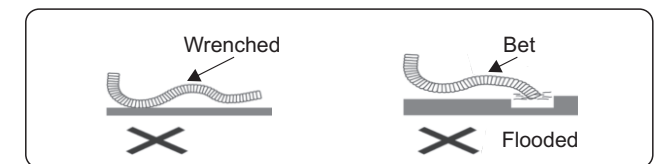

CONNECT INDOOR AND OUTDOOR ELECTRIC WIRES

- 1) Open the surface panel.
- 2) Remove the wiring cover Fig 6.
- 3) Route the power connection cord and signal control wire (for cooling and heating unit only) from the back of the indoor unit and pull it toward the front through the wiring hole for connection.
- 4) Reassemble the clamp and wiring cover.
- 5) Recover the surface panel.

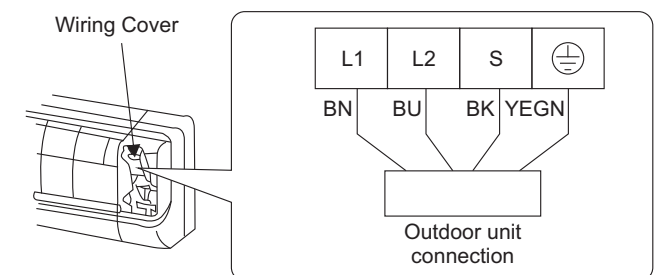

INSTALL INDOOR UNIT

NOTE:

When connecting the electric wire if the wire length is not enough, please contact with the authorized service shop to buy a exclusive electric wire that is long enough and the joint on the wire are not allowed.

- * The electric wiring must be correctly connected, wrong connection may cause spare parts malfunction.
- * Tighten the terminal screw in order to prevent loose.
- * After tighten the screw, slight pull the wire and confirm whether is it firm or not.
- * If the earth wire is wrong connection, that may cause electric shock.
- * The cover plate must be fixed, and tighten the connection wire, if it is poor installed, that the dust, moisture may enter in or the connection terminal will be affected by outside force, and will cause fire or electric shock.

INSTALL THE INDOOR UNIT

The piping can be lead out from right, right rear, left left rear.

- 1) When routing the piping and wiring from the left or right side of indoor unit, cut off the tailings from the chassis n necessary.
 - * Cut off the tailings 1 when routing the wiring only;
 - * Cut off the tailings 1 and tailings 2 when routing both the wiring and piping.

- 2) Take out the piping from body case, wrap the piping electric wire, water pipe with tape and pull them through the piping hole.
- 3) Hange the mounting slots of the indoor unit on the upper tabs of the rear panel and check if it is firm enough.
- 4) The height of the installed location should be 100 inch or more from the floor.
- 5) The water drainage pipe can also be installed on the left of the indoor-unit.

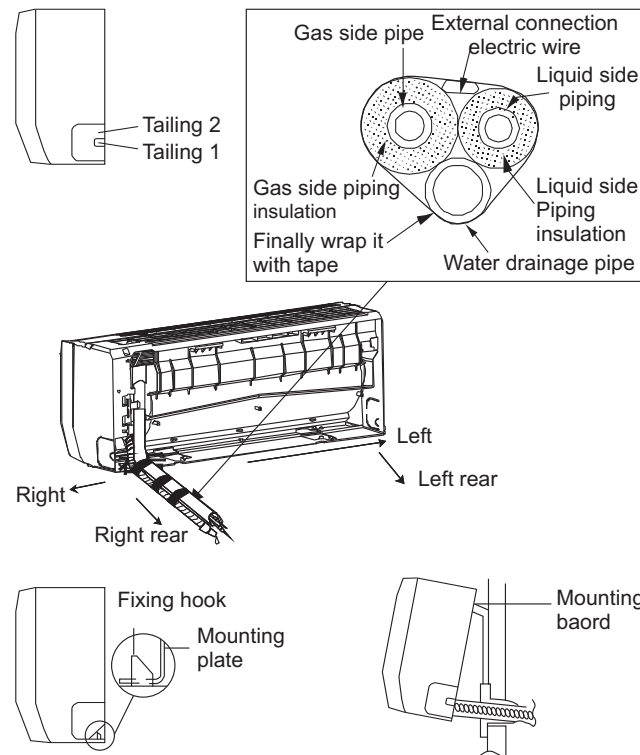

INSTALL THE CONNECTION PIPE

- 1) Align the center of the piping flare with the relevant valve.
- 2) Screw in the flare nut by hand and then tighten the nut with spanner and torque wrench refer to the following:

Hex nut diameter	Tightening torque (N.m)
1/4"	15~20
3/8"	31~35
1/2"	50~55
5/8"	60~65
3/4"	70~75

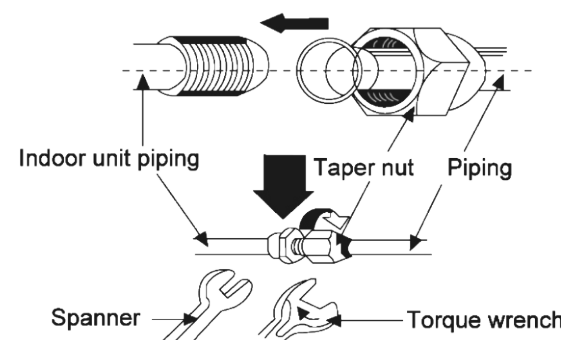

NOTE: Firstly connect the connection pipe to indoor unit, then to outdoor unit; pay attention to the piping bending, do not damage the connection pipe; the joint nut couldn't tighten too much, otherwise it may cause leakage.

INSTALL PV-MODULE

PV-MODULE CHARACTERISTICS

Electrical Characteristics

Open - Circuit Voltage (Voc)	33.4V
Optimum Operating Voltage (Vmp)	26.2V
Short - Circuit Current (Isc)	8.12A
Optimum Operating Current (Imp)	7.63A
Maximum Power at STC (Pmax)	200Wp
Operating Temperature	-40°C to +85°C
Maximum System Voltage	600V DC
Maximum Series Fuse Rating	20AMPS
Power Tolerance	±3 %

Mechanical Characteristics

Solar Cell	Poly-crystalline 156*156mm (6 inch)
No. of Cells	54 (6*9)
Dimensions	1482*992*35mm (58.3*39.1*1.4 inch)
Weight	16.8kg (37.0lbs.)
Front Glass	3.2 mm (0.13inch) tempered glass
Frame	Anodized aluminium alloy
Junction Box	IP65 rated
Output Cables	LAPP (4.0mm2), asymmetrical lengths (-) 1200mm(47.2inch) and (+) 800mm (31.5inch), MC Plug Type IV connectors

STC: Irradiance 1000W/m², Module temperature 25oC, AM=1.5

Current-Voltage & Power-Voltage Curve

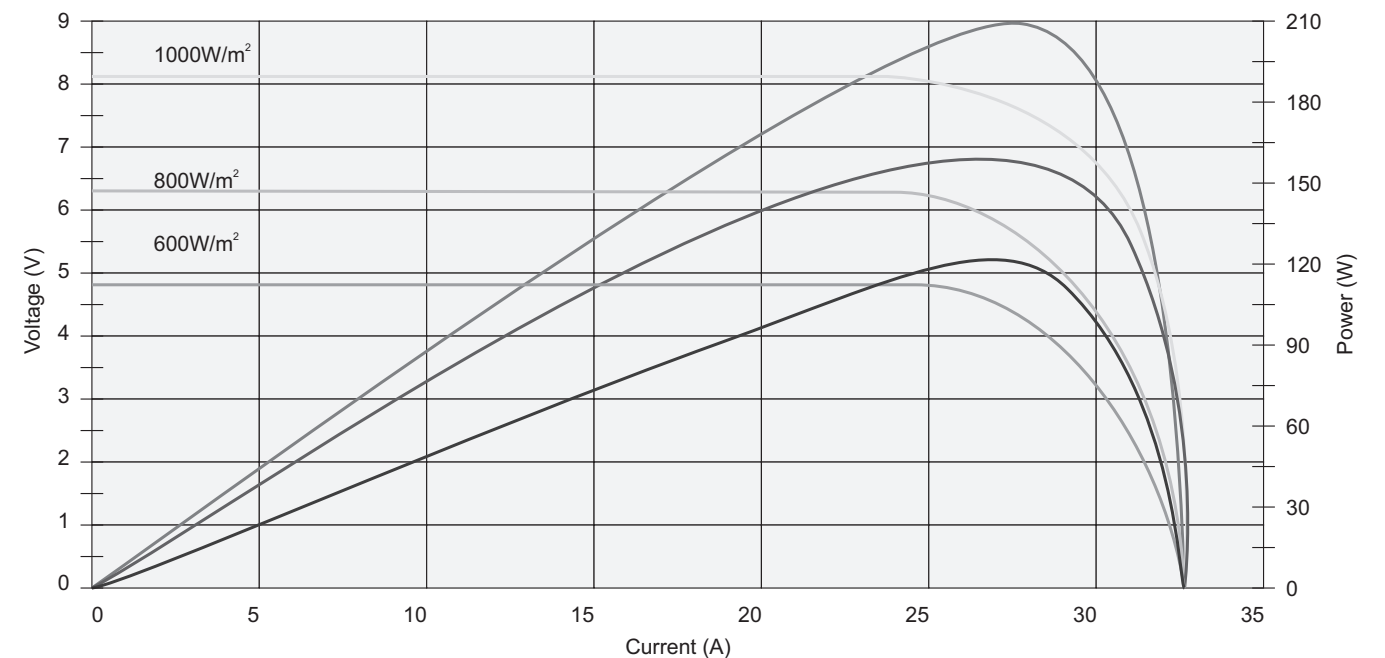

MECHANICAL INSTALLATION

- 1) Mechanical installation of PV-modules should be operated by professional solar photovoltaic installation guides or reputable solar installer of systems integrator.
- 2) Gree do not provide any mechanical installation guide of PV-modules, as a result, gree will not provide any instructor or after service for the problems of mechanical installation of PV-modules.

ELECTRICAL INSTALLATION

General installation

- * Any hardware used must be compatible with the mounting structure material to avoid galvanic corrosion.
- * It is not recommended to use modules with different configurations in the same system.
- * Several modules should be connected in series to form a string of modules if needed. The maximum number of series connected modules is 5.
- * MC-4 connector is the recommended connector and the recommended system wires size is AWG12.

INSTALL PV-MODULE

Installation sketch

Maximum number of PV-modules in one system: 5

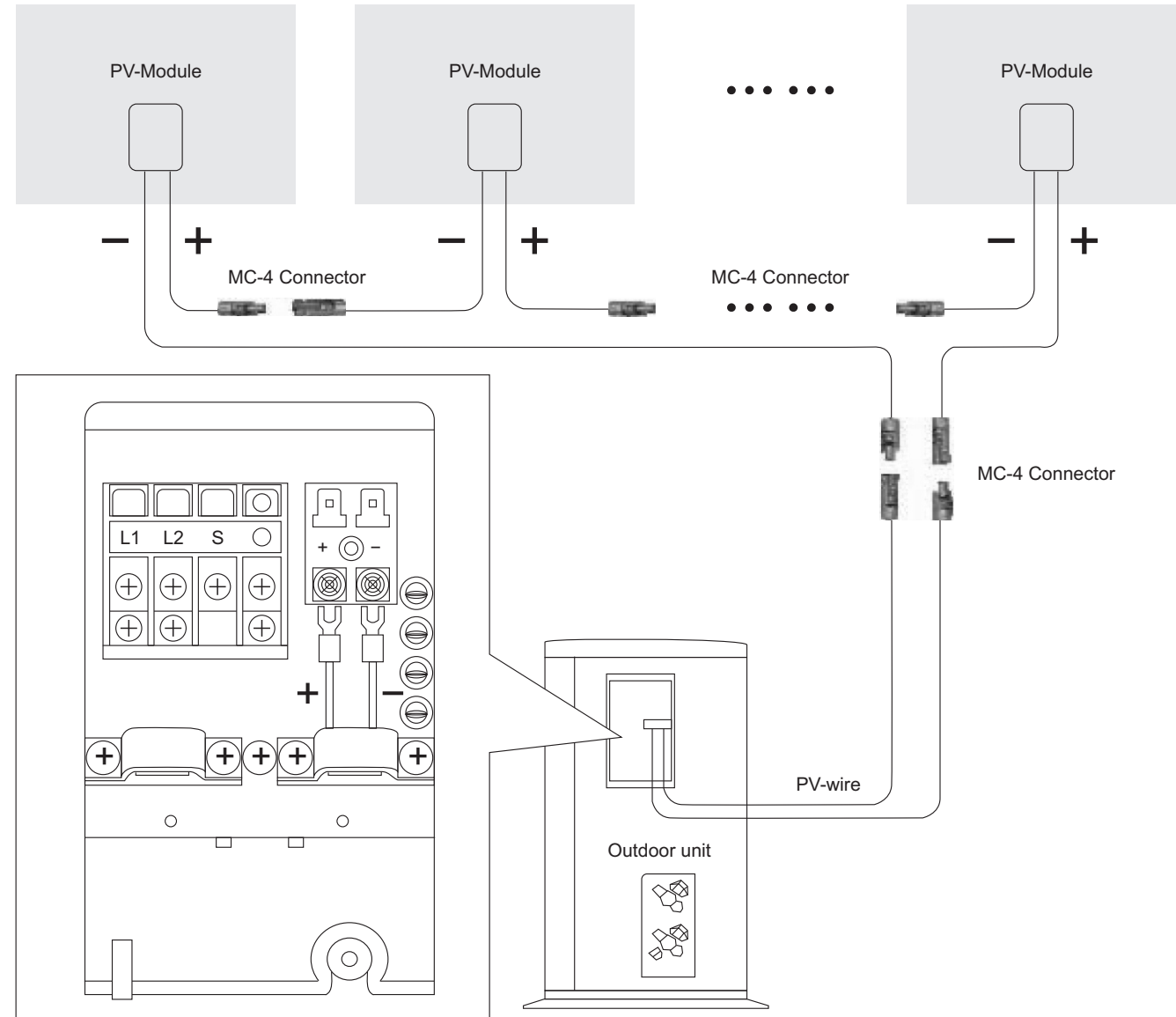

ASSEMBLY OF PV-WIRE

- 1) The PV-wire should be single-pole, double insulated solar cable, the length of which is due to the distance from PV-modules to outdoor unit of AC, the recommended conductor cross section is AWG 12, and it should accord with UL4703
- 2) The MC-4 connectors should be assembled to the PV-wires, and the other side of the PV-wires should be assembled with spade terminals.

MC-4 connectors, connected with PV-modules PV-wires spade terminals, connected with outdoor unit



ASSEMBLY OF MC-4 CONNECTOR

Introduction of MC-4 connector

The MC-4 connector contains three parts, male PV cable coupler (PV-KST4/6II-UR), female PV cable coupler (PV-KBT4/6II-UR) and a safety lock clip (PV-SSH4).

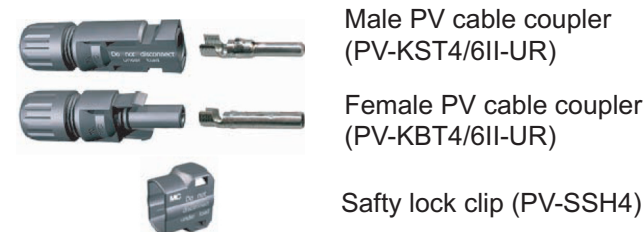

INSTALL PV-MODULE





Assembly method

	Introduction	Photo	Recommended tool
Step1	Strip cable insulation. L = 0.24-0.3 inch. Take care not to cut individual strands.		Stripping pliers: PV-AZM-1.5/6 Interchangeable blade: PV-M-AZM-156
Step2	Open and hold clamping clip (K). Insert contact in the appropriate cross-section range of the crimping tool. Turn contact till crimping tabs face the top. Release clamping clip (K). The contact is secured.		Crimping pliers: PV-CZM-19100 Insert: PV-ES-CZM-19100 Locator: PV-LOC
Step3	Lightly press the pliers together so that the crimping tabs lie securely within the crimping die.		

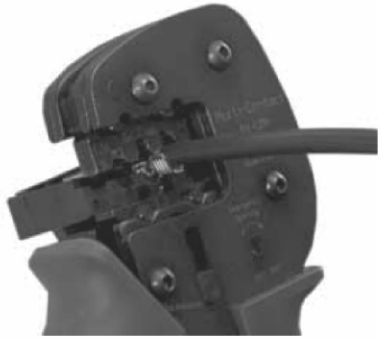
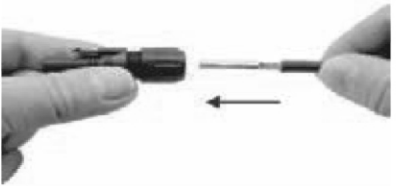
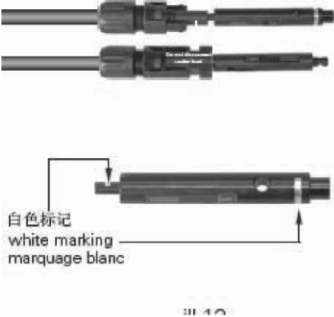

INSTALLER'S INSTRUCTION

INSTALLER'S INSTRUCTION

INSTALL PV-MODULE

<p>Step4</p>	<p>Insert the stripped cable until the insulation comes into contact with the crimping insert. Close crimping tool completely. Check crimp.</p>		
<p>Step5</p>	<p>Push the crimped contact into the socket resp. plug insulator until it engages. Pull lightly on the lead to check that the metal part has engaged.</p>		
<p>Step6</p>	<p>Insert the test pin with the corresponding side into the socket or plug to the end position. If the contact is correctly assembled, the white marking on the test pin must be still visible.</p>	 <p>白色标记 white marking marquage blanc</p>	<p>Test plug PV-PST</p> 
<p>Step7</p>	<p>Screw on the cable gland, hand-tight, with the tools PV-MS. The tightening torque must be adapted to the solar cables used in each specific case. Typical values lie in a range between 2,5Nm to 3Nm.</p>		<p>Open-end spanner PV-MS 1 set = 2 pieces</p> 

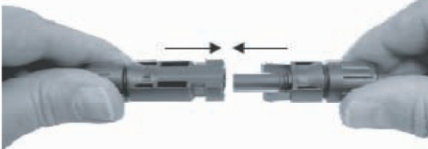
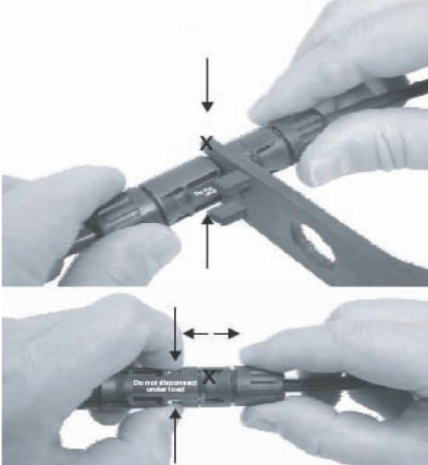
INSTALL PV-MODULE

<p>Step8</p>	<p>Plug the coupling together until they engage. Check correct engagement by pulling on the coupling.</p>		
<p>Step9</p>	<p>Compress the two snapin springs (X) by hand or with the PV-MS tool and separate the coupling.</p>		
<p>Step10</p>	<p>Plugging: Mount the plug connection until it engages. Check correct engagement by pulling on the coupling. Unplugging: The plug connection can only be unlocked with the tool PV-MS.</p>	 <p>PV-SSH4</p>	<p>PV-SSH4</p> 

CHECK AFTER INSTALLATION AND TEST OPERATION

TEST OPERATION

1) Before test operation

- 1) Do not turn on power before installation is finished completely.
- 2) Electric wires must be connected correctly and securely.
- 3) Cut-off valves of the connection pipes should be back seated/tuned on.
- 4) All the impurities such as scraps and thrums must be cleared out of the unit.

2) Test operation method

- 1) Switch on power, press "ON/OFF" button on the wireless remote control to start the operation.

- 2) Press MODE button, to select the COOL, HEAT (not available for cooling only unit is), FAN and so on to check :

* All the functions (to make sure the unit functions correctly and properly).

* Refrigerant (pressures/temperatures at service values/pipes should be good).

* Drainage (condensate/water flow should be dripping out of drainage pipe ONLY).

* Noise (there should be not any abnormal sound).

CHECK AFTER INSTALLATION AND TEST OPERATION

CHECK AFTER INSTALLATION

Items to be Checked	Possible If Not Followed, Consequences
Has the unit been positioned firmly?	The unit may drop, shake or emit noise.
Have you done the refrigerant leakage test?	It may cause insufficient cooling(heating), or compressor overheating, or other unit malfunctions.
Is heat insulation sufficient?	It may cause unexpected condensate and dripping.
Is drainage pipe tested ?	It may cause leakage or unexpect dripping.
Is the voltage in accordance with the rated voltage marked on the nameplate?	It may cause unit malfunction or damage to the part/unit.
Is the electrical wires and pipes connection installed correctly and securely?	It may cause unit malfunction or damage to the part/unit.
Has the unit been connected to a secure ground connection?	It may cause electric leakage.
Is the power cord specified properly per NEC codes ?	It may cause wire overheat or even fire.
Is the air inlet and outlet been cleared?	It may cause insufficient cooling/heating capacity, and unexpected noise.
Has refrigerant charge been adjusted to match the capacity or rated level?	The unit may generate extra noise, pipes being iced up overheated, or insufficient cooling or heating, etc.

INSTALLATION AND MAINTENANCE OF HEALTHY FILTER

INSTALLATION INSTRUCTIONS

- 1) Forcibly lift up the panel at a specific angle from the two ends of the front panel following the arrow direction. Then pull the air filter downwards to remove it. (Fig.a)
- 2) Mount the healthy filter onto the air filter, (Fig.b). If the air filter cannot be installed, please mount the healthy filter on the front case. (Fig.c)
- 3) Mount the air filter properly along the arrow direction in Fig.d, and then close the panel cover.

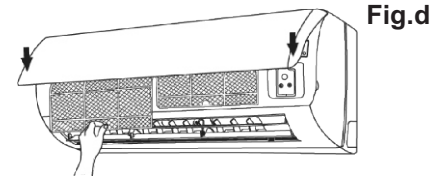
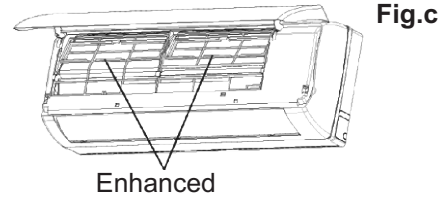
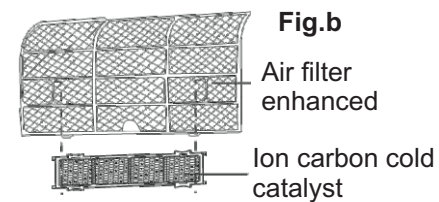
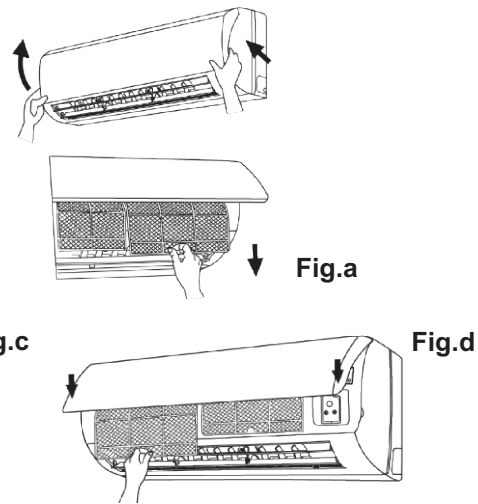

CLEANING AND MAINTENANCE (Regular Filter and/or Other Enhanced Filters)

Take out the (enhanced) filter before cleaning according to the installation instruction. Pay special attention that silver ion filter can't be cleaned with water, while active carbon, photo catalyst, low temperature conversion (LTC) catalyst, formaldehyde eliminator, ca-techin or mite killing filter can (but can't be cleaned with brush or hard/sharp tools). Dry and reinstall it after cleaning. Make sure to replace securely and properly.

FILTER LIFETIME

The washable filter will last a long time. But some (enhanced) filters may only have a lifetime about one year under normal condition. As far as the silver ion filter, it will turn into invalid when its surface becomes black (green).

REMOTE CONTROL-BUTTON NAME & FUNCTIONS

NOTE1: This is a general use remote control. That can be used for numerous air conditioning model numbers. There may be some buttons on the remote that are not for use with the unit purchased. When these buttons are pressed you may hear a beep sound emitted from the remote. This will not affect the unit status.

NOTE2: Be sure there are no obstructions between the indoor unit and the remote control. Do not drop or allow any liquids near the remote. Do not place the remote in direct sunlight or any place that can become very hot.

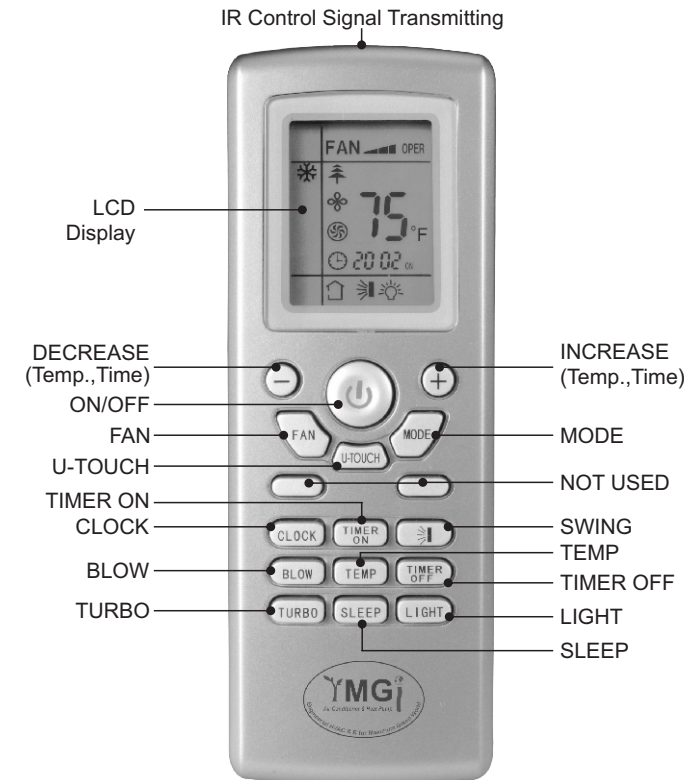

"ON/OFF" BUTTON: Press this button to turn the unit on. Press once more to turn the unit off. When turning the unit ON/OFF, the TIMER, and SLEEP functions will be canceled. The preset time will remain.

"MODE" BUTTON: By pressing this button you can choose what mode you would like the unit to run in. When the remote is first turned on the mode displayed will be the AUTO mode. The temperature cannot be adjusted in this mode and will not display on the indoor unit. This is a factory preset temperature of 78°F. While the unit is in AUTO mode if the room temperature drops below the factory set temp of 78°F then the unit will run in HEAT mode until that temperature is satisfied. If the room temperature rises above the set temp of 78°F then the unit will run in COOL mode until the room temperature is satisfied. The unit itself will determine what mode to run in order to maintain the temperature of 78°F. Under HEAT mode the initial set temp will be 82°F (28°C). Under other mode the initial set temp will be 77°F.

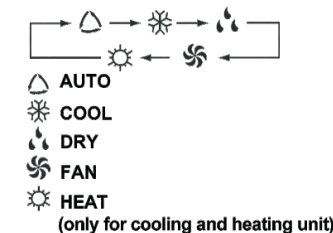

"SLEEP" BUTTON: This function will increase or decrease the set temp depending on what mode the unit is running in. When SLEEP mode is turned on in cooling mode the temp will automatically increase 0.5 to 1.0 degree once every half to one hour for several times over a period of 2 hours and remain at that temperature until SLEEP mode is turned off. When SLEEP mode is turned on in heating mode the set temp will automatically decrease 0.5 to 1.0 degree once every half to one hour for several times over a period of 2 hours and remain at that temperature until SLEEP mode is turned off. This way when the unit is SLEEP mode during cooling the fan will blow at a lower speed to accommodate for the decreased cooling load due to less activity and a lower outdoor temp. The same principle of savings is applied to heat mode.

To activate the sleep mode press the SLEEP button once. You will see a picture of a moon and stars in the lower left hand corner. To turn off the SLEEP mode simply press the button once more and the moon and stars will disappear from the remote screen.

The COOL mode SLEEP profile is as follows:

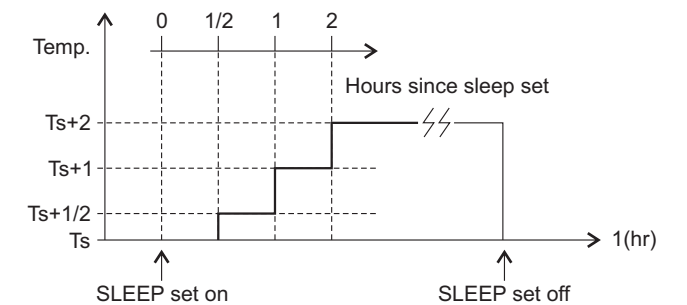

The HEAT mode SLEEP profile is as follows:

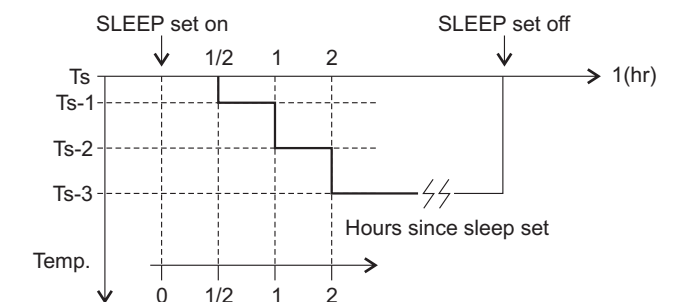

REMOTE CONTROL-BUTTON NAME & FUNCTIONS

"FAN" BUTTON: By pressing this button you can select from fan speeds AUTO→Low→Middle→High. When the unit is first powered on the default fan speed setting is AUTO. When running the unit in DRY mode the fan speed will only run in low speed.



Note: Under the Dry mode, the fan speed isn't adjustable, low fan speed is imperative.

"BLOW" BUTTON: When the blow function is on a symbol on the remote will appear next to left hand corner of the temp. This feature when turned on, will allow the indoor fan to continue to blow even when the unit is turned off by the remote. This will aid in the quick drying of the indoor coil to help prevent any kind of mold build up due to moisture. To turn this feature off simply press the BLOW button once more till you notice the blow icon disappear from the remote display.

"TURBO" BUTTON: When you press this button you will see a symbol of a fan appear on the remote. In either heat or cooling mode when this button is pushed the compressor and or fan will blow at a higher speed to achieve set temp quicker. When the indoor unit senses that the set temp is being approached the fan speed will slow down. To turn this function off simply press the TURBO button until the fan symbol is no longer displayed on the remote.

"+" Button: By pressing this button the set temp will increase. If this button is pushed without releasing for over 2 seconds the temperature will increase more rapidly. In AUTO mode the temperature cannot be changed. The temperature range for this remote is 61°F to 86°F.

"-" Button: By pressing this button the set temp will decrease. If this button is pushed without releasing for over 2 seconds the temperature will decrease more rapidly. In AUTO mode the temperature cannot be changed. The temperature range for this remote is 61°F to 86°F.

"TEMP" Button: When the unit is first turned on the remote will display the last set temp. When the TEMP button is pushed twice the indoor unit will display the room temp for approximately 5 seconds before going back to the set temp.

TO LOCK THE REMOTE: If you would like to lock the remote from anyone changing the settings simply press the "+" and the "-" buttons simultaneously. When the remote is locked you will see an icon of a lock appear on the remote. If while the remote is locked and someone pushes a button on the remote they will see the icon of the remote flash three times. This indicates the remote is locked. To unlock the remote simply press the "-" and the "+" once more. You will know the remote is unlocked once the icon of the lock disappears from the remote screen.

SWITCH BETWEEN F° AND C°: The remote default is Fahrenheit. If you would like to switch between the remote displaying Fahrenheit and Celsius the MODE and the "-" button simultaneously while the unit is turned off.

"TIMER ON" BUTTON: This button allows you to set a time you would like the unit to turn on. The clock is a 24 hour clock. Press the TIMER ON button once and you will see the word "on" flashing next to a time displayed. By pressing either the + or the - button choose the time you would like the unit to turn on. Once you have the desired time displayed on the remote press the TIMER ON button once more and the word ON will stop blinking and stay on the remote. The time you would like the unit to turn on is now set.

"TIMER OFF" BUTTON: This allows you to set the time that you would like the unit to shut off. Simply follow the above steps but this time press the TIMER OFF button instead of the TIMER ON button. When the word OFF is set on the remote screen, the time you would like the unit to turn off is now set.

"CLOCK" BUTTON: The time function runs on a 24 hour clock. To set the time press the clock button once. You will see a flashing clock appear on the remote. Press the "+" button to increase the time; press the "-" button to decrease the time until the desired time is set. Press the clock button once more to set the time. You will notice then, the clock symbol is not flashing.

"LIGHT" BUTTON: This allows you to turn the indoor unit display light on and off. If the light emitted by the display is bothersome simply press the LIGHT button on the remote and the display will turn off. To turn the display back on simply press the light button once more.

REMOTE CONTROL-BUTTON NAME & FUNCTIONS

"SWING" BUTTON: Hold the swing button (symbol shown above) for more than 2 seconds and the indoor air louver will start to swing between the highest and lowest limits. Once the swing button is released the louver will stay in the last position where the button was released.

If the swing button is pushed just once the swing icon will appear on the remote and the louver will swing up and down continuously between the highest and lowest points. Push the swing button once more and the icon will disappear on the remote and the louver will remain at the last point the button was pushed. When the unit is powered off by the remote the louver will close on the indoor unit. Press this button to set up the desired swing angle which circularly changes as below. (Insert swing picture)

"U-TOUCH" BUTTON: Since the indoor unit is normally mounted high up on the wall or attached to the ceiling, the temperature at where the return air sensor is installed inside the indoor unit is higher than what it is where the area people stand and can feel (4 to 7 feet above the floor). If the unit uses the return air temperature as its target control, people may feel colder than what they really want (target) in both cooling mode and heating mode. The facts of air stratification and warm air rising and cold air dropping require users to set up, by experiments or experience, the target temperature quite few degrees higher than what you really want, in order to reach a satisfied or more precise indoor comfort. This is a common drawback of AC/HP units made by other manufacturers. With YMGI's U-touch feature, this can be avoided and your comfort level can be improved. When you press the U-TOUCH button on the remote control, the unit will use the temperature where the remote is located as its target temperature control. Once you do so, you will notice a figure of a person surrounded by stars appear on the remote.

Once the U-TOUCH stars appear, the remote will send a signal of the remote-local temperature to the indoor unit, and this remote-local temperature will supersede the return air temperature as the unit's target temperature. Every 10 minutes such signal will be sent from the remote to the indoor unit updating the remote-local temperature. If at any time during this process no signal is received by the indoor unit from the remote, the unit will switch back to the previously set temperature before the U-TOUCH feature is activated. To turn the U-TOUCH feature off, simply press the U-TOUCH button until you see the symbol disappear from the remote screen. By doing so, the return air temperature will take place of remote-local temperature as the unit's target temperature. U-TOUCH is what YOU WANT. U-TOUCH feature brings to you a true comfort level wherever and whenever you want.

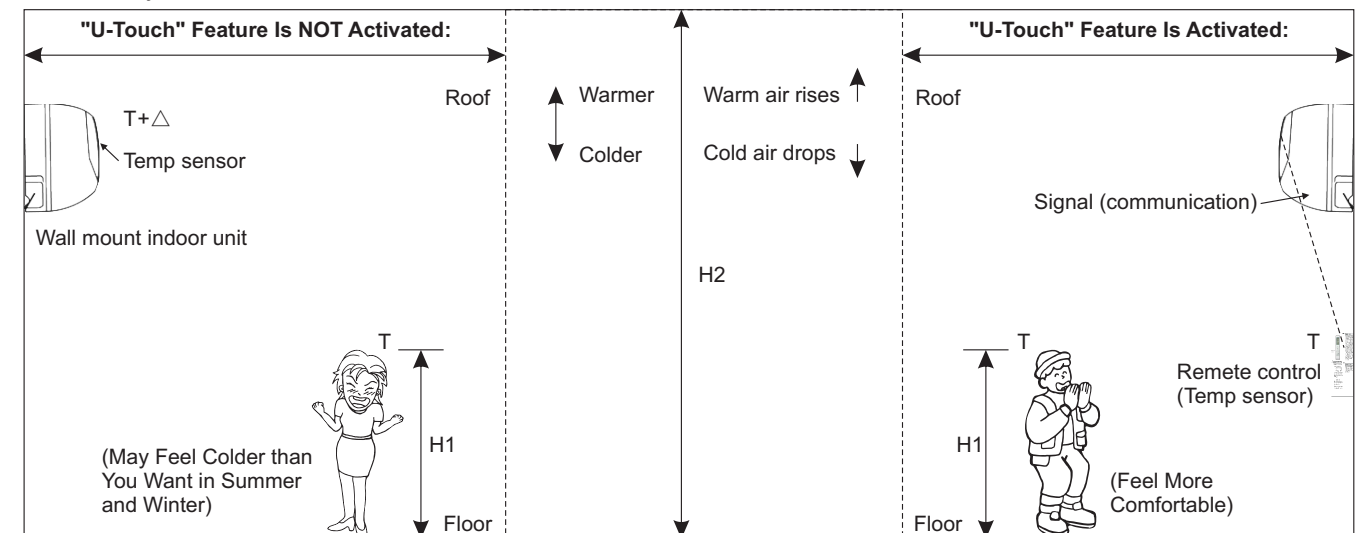

"SWING UP AND DOWN" BUTTON

Press this button, to set up swing angle, which circularly changes as below:



This is an universal use remote control. If remote control sends the following three kinds of status that the swing status of main unit will be:

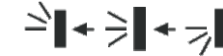

When the guide louver start to swing up and down, if turn off the Swing, the air guide louver will stop at current position.

which indicates the guide louver swings up and down between that all five positions.

REMOTE CONTROL-BUTTON NAME & FUNCTIONS

SYMBOL DISPLAY

When power is first applied to the unit but the power has not been turned on by the remote control, then the red power light only is displayed. When the unit has been powered on by the remote control then the running LED is lit and the current running mode symbol is displayed at the same time.

COOLING: Running symbol and cooling symbol are lit.

HEATING: Running lamp and heating symbol are lit.

DRY: Running lamp and dry lamp are lit.

FAN: Running lamp and fan lamp are lit.

AUTO: Auto lamp, running lamp and actual running mode are lit.

ALPHA NUMERIC DISPLAY

* The setting temperature range for the unit is 61° to 86°F.

* Under AUTO mode unit will display 77°F for cooling and 68°F for heating modes.

INTRODUCTION FOR SPECIAL FUNCTION

About blow function

This function indicates that there is moisture on the evaporator of the indoor unit will be blown after the unit has stopped to avoid mold.

- 1) Having set blow function on: After turning off the unit by pressing ON/OFF button indoor fan will continue running for about 10 min. at low speed. In this period, press blow button to stop indoor fan directly.
- 2) Having set blow function off: After turning off the unit by pressing ON/OFF button, the complete unit will be off directly.

About AUTO RUN

When AUTO RUN mode is selected, the setting temperature will not be displayed on the LCD, the unit will be in accordance with the room temp. automatically to select the suitable running method and to make ambient comfortable.



* About turbo function

At the start of this function, the unit will blow at super high speed to cool or heat quickly so that the room temp. approaches the preset temp. as soon as possible.

* About lock

Press + and - buttons simultaneously to lock or unlock the keyboard. If the remote controller is locked, the icon  will be displayed on it, in which case, press any button, the mark will flicker for three times. If the keyboard is unlocked, the mark will disappear.

* About swing up and down

- 1) Press swing up and down button continuously more than 2s, the main unit will swing back and forth from up to down, and then loosen the button, the unit will stop swinging and present position of guide louver will be kept immediately.
- 2) Under swing up and down mode, when the status is switched from off to , if press this button again 2s later,  status will switch to off status directly; if press this button again within 2s, the change of swing status will also depend on the circulation sequence stated above.

OPERATION OF REMOTE CONTROL

UNIT DEFROSTING CYCLE

While the unit is running in HEAT mode during colder weather, frost can build up on the outdoor coil. This is common on all heat pump units made by all manufactures. If the unit is running and the automatic defrost mode is enacted the indoor unit will stop running and display an H1 code. Once the defrost cycle is finished and the outdoor coil is defrosted the indoor unit will start to run again in the mode that it was last set up for.

ON DEMAND DEFROSTING

If at any time you would like to send the unit into the defrost cycle, you can choose to by turning the remote controller off and pressing the BLOW and the MODE buttons simultaneously. You will see the symbol of H1 appear on the remote. To stop the defrost cycle simply press the BLOW and MODE buttons again and the H1 will disappear from the remote screen.

OPERATION OF REMOTE CONTROL

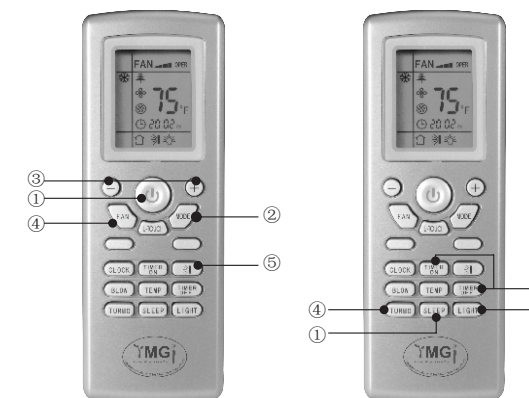

CHANGING BATTERIES AND NOTICES

- 1) Press slightly along the arrowhead direction to push the back cover open on remote control.
- 2) Take out the old batteries. (As show in figure)
- 3) Insert two new AAA1.5V dry batteries, and pay attention to the polarity. (As show in figure)
- 4) Attach the back cover of wireless remote control. (As show in figure)

NOTE:

When changing the batteries, do not use the old or different batteries, otherwise, it can cause the malfunction of the wireless remote control.

If the wireless remote control will not be used for an extended period of time, it is recommended to leave the batteries out as this could cause leakage from the batteries. This will damage the remote control.

The operation should be in its receiving range.

It should be placed at where is 1m away from the TV set or stereo sound sets.

If the wireless remote control can not operate normally, please take them out, after 30s later and reinsert, if they cannot normally run, please change them.

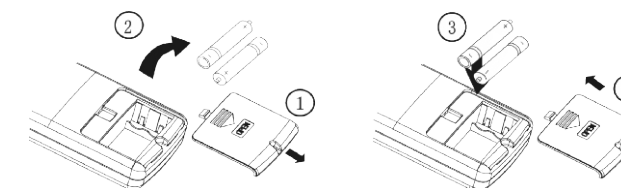

Sketch map for changing batteries

EMERGENCY OPERATION

When the wireless remote control is lost or damaged, please use the manual switch, at this time, it is running in Auto Run mode that will not change the temperature setting value and fan speed.

The manual switch can be operated as follow:

- * At operation: When the unit has stopped running, press ON/OFF button, unit will enter into AUTO RUN mode. The microcomputer will accord to the room temperature to select the (COOL, HEAT, FAN) mode automatically, to obtain the comfortable effect.
- * At stopping: When the unit is running, press the ON/OFF button of the manual switch, the unit will stop work.

The code switch can be operated as follow:

- * At operation: When the unit is stopped running, adjust the code switch to AUTO, the unit will enter into AUTO RUN mode. The microcomputer will accord to the room temperature to select the (COOL, HEAT, FAN) mode automatically, to obtain the comfortable effect.
- * At stopping: When the unit is running, adjusts the code switch to STOP position, the unit will stop work.

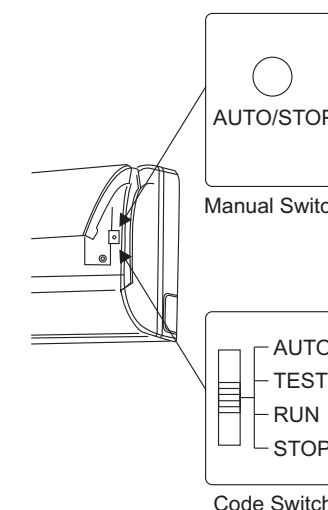

CLEAN AND CARE

⚠ CAUTION

- * Before cleaning the unit, turn power off by remote control and then disconnect the electrical power at outdoor unit.
- * Never sprinkle water on the indoor unit and the outdoor unit.
- * Volatile liquid (gasoline or the like) will damage the unit. (So wipe the units with a dry soft cloth, or a cloth slightly dipped with water or cleanser.)

CLEAN THE FRONT PANEL

Dip the cloth into the water temperature of 113°F below, twist it to squeeze out extra water before starting to wipe the panel.

Do not to immerse the front panel in water. There are microcomputer components and circuit diagrams on the front panel, which are to be damaged if being put into water.

CLEAN THE AIR FILTER (RECOMMENDED ONCE EVERY THREE MONTHS)

NOTE: If there is some dust around the unit, the air filters should be cleaned many times. After taking off the filter, don't touch the fin of indoor unit, in order to avoid any potential finger or skin injury.

REMOVE THE AIR FILTER

At the slot of surface panel to open an angle, pull the air filter downward and take it out, please see (Fig. a, b).

CLEAN THE AIR FILTER

To clean the dust adhering to the filters, you can either use a vacuum cleaner (Fig. c), or wash them with warm water (below mixed 113°F) mixed with neutral detergent, and then air-dry it in shade.

NOTE: Never use water above 113°F to clean, or it can cause deformation or discolouration. Never try to dry it close by fire, or it can be deformed.

INSERT THE AIR FILTER

Reinsert the filters along the direction of arrowhead, and then to cover back the cover (Fig. d).

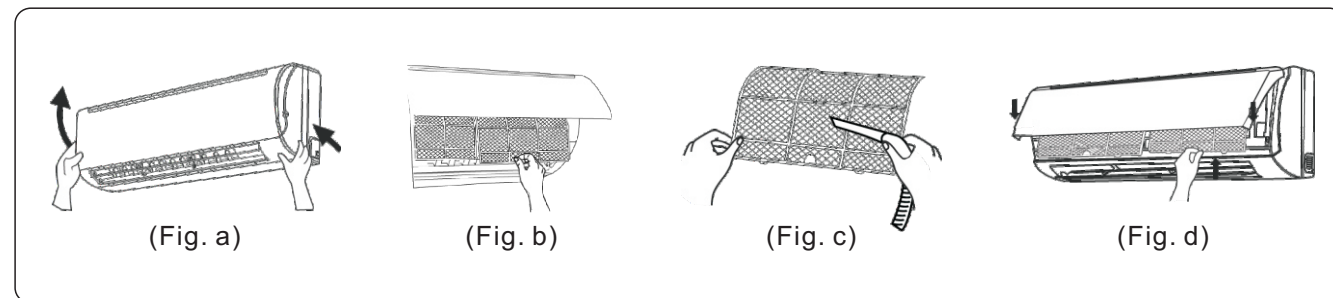

CHECKING BEFORE SEASON COMES:

- 1) If the unit is still connected to the correct electric power V/Ph/Hz.
- 2) If the unit is still securely fastened..
- 3) If the batteries of remote control are good.
- 4) If the filter is loaded and clean
- 5) If the intake and discharge vents are clear from any obstruction.

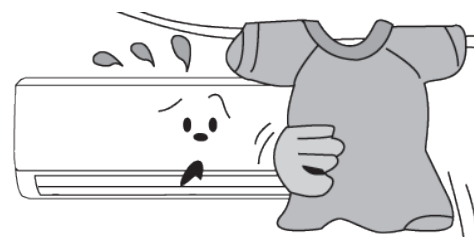

MAINTENANCE AFTER USING

- 1) Turn main power off, by disconnecting electrical power disconnect switch.
- 2) Clean filter and unit.
- 3) Cover unit to keep from dust or moisture.

TROUBLE SHOOTING

⚠ WARNING

Do not repair the air conditioner at your discretion. Incorrect repair may cause electric shock or fire, so please contact authorized service center for professional repair.

Following checks prior to contact may save your time and costs.

Phenomenon	Normal or Abnormal
<p>The unit doesn't deliver cooling or heating, immediately after the unit is restarted (remote control or power resuming).</p>	<p>If unit is powered off, and then restored, it will not run the compressor until 3 minutes later. This is normal 3-minutes restarting protection against high internal refrigerant pressure.</p>
<p>The unit blows smell.</p>	<p>For new unit, some of the smell is normal. For any bad or abnormal smell, need to shut off the unit and check around. May need to call your technician.</p>
<p>Hearing sound of "water flow" inside unit.</p>	<p>Normally this is due to refrigerant flowing through coils.</p>
<p>Mist is blown out of unit.</p>	<p>Normally it happens during cooling start period, when indoor air is hot and humid.</p>
<p>Hearing creaking noise during unit starting or shutting off.</p>	<p>Normally this is caused by the expansion or contraction at components due to the temperature changes.</p>
<p>The unit doesn't operate at all.</p>	<ol style="list-style-type: none"> 1) Is power shut off or lost? 2) Is TIMER set up? 3) Is circuit breaker not engaged, or even trips? 4) Is fuse not connected, or even blown? 5) Is voltage too high or low? 6) Is the flow control or other switches breaking the circuit? 7) Is unit under 3-minute restarting protection period? 8) Is the remote control out of battery power?

TROUBLE SHOOTING

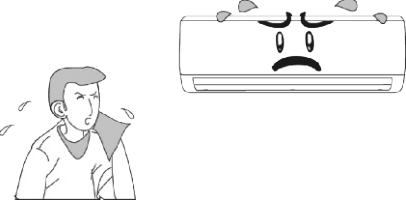
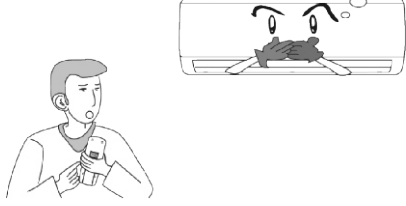
Phenomenon	Normal or Abnormal
Unit doesn't respond to remote control. 	1) Is the remote control out of battery power? 2) Is remote control pointing to sunshine or lighting? 3) Is remote control signal blocked? 4) Is remote control too far away from indoor unit? 5) Is the fuse on indoor unit blown? 6) Is the indoor unit powered on? 7) Is the indoor unit transformer good? 8) Is the indoor unit control board good?
Cooling (heating) is not powerful. 	1) Is the set temperature too high or too low? 2) Is filter dirty? 3) Is air vent blocked? 4) Is unit undersized? 5) Is window or door closed? 6) Is unit refrigerant at lower level? 7) Is outdoor too hot or cold? 8) Is fan speed set at low?
Indoor unit doesn't blow air.	1) Is the unit in 3-minutes restarting protection period? 2) In heating mode, the indoor fan motor will not rotate before the indoor coil is hot enough. This is a normal anti-cold air blowing function. 3) Is the outdoor unit defrosting? 4) Is the unit in fan-pausing period of dehumidification mode? 5) Is the filter dirty? 6) Is the fan motor setting screw loose? 7) Is the fan capacitor bad? 8) Is the fan motor bad?
Condensate forms at air discharge louver.	This is normal when the conditioned cool air is mixed with the warm/hot and humid indoor air. Condensate may go away gradually once the indoor air is dehumidified and cooled down.
Water drips out of indoor unit.	1) Is indoor air too warm and humid? 2) Is condensate drain hose/connection leaking? 3) Is condensate drain hose clogged or restricted? 4) Is condensate drain hose insulated? 5) Is the 3" hole at exterior wall staffed or sealed?
Noise is heard at indoor unit.	1) Is the fan motor or compressor relay energized? 2) Is it due to temperature change that causes part expansion or contraction?
Must stop all unit operations, disconnect power and contact your service technician, in the following situations:	
1) Harsh sound is heard; 2) Bad odor is smelt; 3) Water is leaked out of indoor unit; 4) Circuit breaker trips or fuse is blown few times;	5) Wires or connections are very hot; 6) Oil or refrigerant leakage is found; 7) Unit vibrates abnormally; 8) Other abnormal situations.

CUSTOMER AND TECHNICIAN MUST READ

WHY DOES YMGI GROUP REQUIRE INSTALLATION AND SERVICE TO BE 100% PERFORMED BY LICENSED OR CERTIFIED HVAC TECHNICIAN/ CONTRACTOR?

- 1) They have the training and experience to accurately and safely install and service your equipment.**
The equipment runs with high-pressure refrigerant and oil and line-voltage. The copper lines must be installed properly to prevent leakage and foreign substances from contaminating the refrigerant system.
- 2) You will save money in the long run.** If any problems occur on the unit that is fully installed by the licensed or certified contractor, they have the training and experience to correct the problem more efficiently. A technician(s) may be unwilling to repair an issue on a unit that they did not install. If you do find a technician willing to perform the service, there is an increased possibility of higher service fees than normal, increased service visits, or delayed service from that technician.
- 3) It's the law!**
The federal, state and/or local government and authorities have various governing laws or regulations, guidelines, ordinances, etc., requiring only licensed or certified professionals can install and service high pressure HVAC equipment.

SUGGESTIONS, TO AID YOU IN HIRING AN HVAC CONTRACTOR:

- Hire a currently, practicing, licensed/ certified HVAC technician/ contractor. Technicians, who are no longer practicing (retired, etc.) in this field, may not have the updated knowledge or may lack experience on the equipment you have purchased.
- Hire a technician/ contractor who services customers in your local area and you are familiar with. Local contractors have a faster response time and will be easier for you to determine if they are reputable.
- Use only reputable licensed/ certified HVAC installation contractors/ technicians to prevent any unexpected charges as a result from unethical business practices.
- Check their references, to verify they are a good service provider to the general customers. N.A.T.E or A.C.C.A certified technicians are strongly recommended.
- Some contractors/ technicians may not feel comfortable about installing the equipment that you purchased for them to install, and they prefer to purchase and install the equipment. You can contact YMGI directly to check and see if there have been any contractors in your area who have installed our products or similar.
- Ask for a detailed quote for the whole installation project. A flat rate quote is the safest contract for both you and the contractor
- Your local HVAC technicians may charge you on a project basis or on an hourly basis. To our general knowledge and experience, **a full single head installation may normally cost anywhere from \$800 to \$1500.** These costs are estimates and your actual costs may differ due to job nature and location.
- Number of hours can vary depending upon each individual situation, some factors are, but not limited to:
- How difficult or complex the indoor unit is to be securely installed.
- How difficult or how long the inter-connecting pipes and wires are to be installed.

CUSTOMER AND TECHNICIAN MUST READ

- 11) If all the suggestions have been taken and all the necessary steps are followed.
- 12) If the contractor(s)/technician(s) are experienced with the systems/brands you purchase.
You might spend less. But remember, many times you get what you pay for.
- 13) Sign a contract with them. The contract should list all the detailed work they will conduct and the standards they will follow. Some contractors are willing to include a 1-year installation/service warranty at no extra charge. Check with them to see if that is available. If available, include that in the contract.
- 14) Verify and confirm the installation is done completely and all the unit functions have been checked and are working properly, all the items in the checklist have been checked and marked well in the warranty registration card/form, prior to paying the contractor in full.

The cost of not having your unit installed properly can be more expensive than spending a little extra money that hiring the right contractor will cost. Protect your investment and warranty eligibility by doing it right first time.

UPON PURCHASING, OPENING PACKING BOXES AND INSTALLATION OF YMGI UNITS/ACCESSORIES, YOU AND TECHNICIANS YOU HIRE TO INSTALL THEM ARE ASSUMED TO HAVE READ ALL MATERIALS AND AGREE TO FOLLOW AND BE BONDED BY ALL WE SAY IN YMGI MANUALS.

- 1) You understand all that is written hereafter in this and other documents that we publish.
- 2) You will follow what is written hereafter in this and other documents that we publish.
- 3) You will be bound by and completely follow all policies, guidelines, instructions, warnings, attentions and other materials, as published by YMGI Group, its subsidiaries or sister companies, in writing.
- 4) Only a successful installation, fully (100%) conducted by a qualified HVAC technician(s), as detailed in the checklist of the **Limited Product Warranty Policy** and **Limited Product Warranty Registration Card/Form**, along with a properly detailed installation invoice, is eligible for the **Limited Product Warranty**.
- 5) Failure to follow what is written hereafter may cause various equipment issues that you will take full responsibility and liability for, including, but not limited to, losing manufacturer's warranty, unit not working properly, unit malfunctions, under-performance, decreased safety, increased potential of various damages to your property, body, home and/or business, etc.
- 6) YMGI documents and policies supersede those made or provided by the sales distributors or installing contractors. YMGI Group maintains the final authority in explaining and resolving any and all discrepancies that might exist between distributors/contractors' documents and ours.

YMGI STRONGLY RECOMMENDS:

- * Customer hires a currently licensed/ certified HVAC technician(s) (N.A.T.E. or A.C.C.A certification is strongly recommended) to conduct 100% of the installation, inspection of all unit functions and repair service.
- * Customer signs an installation/service contract with the installation/service technician's company who has good service references and you trust. Installation and service is very important to the life of your investment and provide you a lifetime of comfort and peace of mind.
- * Customer requests the installer to put down a 1-year labor warranty coverage in the installation contract.
- * Have the technician check against all the items in the checklist of the **Limited Product Warranty Registration Card/Form**, sign and date it, to help ensure a proper and professional installation.
- * Customer pays in full, only after all the unit functions are inspected, the unit works properly, warranty checklist is fully filled out and signed and you are fully satisfied.
- * If any unit abnormality is found, have your technician check the unit first. Have them call for manufacturer technical assistance, if necessary, from your job site, not his office, so that we can more accurately assist him in diagnosing the cause of the malfunction.

QUESTIONS ABOUT SELF-INSTALLATION VS HIRING LICENSED HVAC TECHNICIANS

Does YMGI allow to do-it-yourself installations (DIY) partially or fully? NO.

Unfortunately no brand or manufacturer can take the responsibility of the equipment if it is not professionally installed by a currently licensed HVAC technician/ contractor.

If unit is installed by non-licensed people, in part or fully, will the factory warranty be void? YES.

CUSTOMER AND TECHNICIAN MUST READ

Some DIY installations have been successful, but these are exceptions. Most have resulted in equipment failure, due to lack of knowledge and experience. A few of the problems result from DIY's lack of knowledge in the following areas:

- * Sizing and selecting correct type, size and model of cooling and/or heating equipment.
- * Sizing and installing correct electric circuit breakers and wires.
- * Wiring the units correctly and properly.
- * Taping the ends, connecting to indoor and outdoor units correctly and properly.
- * Vacuuming the inter-connecting refrigerant lines.
- * Checking and/or fixing the refrigerant leaks.
- * Checking and/or fixing the condensate drain leaks.
- * Releasing the refrigerant from outdoor unit to indoor unit.
- * Running the unit to check all the unit functions.
- * Conducting the installation or trouble-shooting with correct tools, experience or professional knowledge to correct the problem.

RECEIVING AND FREIGHT DAMAGE

- * Freight (package/unit) shall be checked thoroughly for damage at receiving before accepting by signing on the carrier's delivery paperwork.
- * Upon shipment being signed for acceptance, it becomes a binding document as to the condition of the products on delivery. We cannot process any shipping damage claim, if you accept the delivery.
- * If damage is found at delivery, both you and the delivery driver must make notes on the delivery receipt or other freight paperwork detailing the damage found by marking position/parts on unit, description of damage, time/date, your name, contact phone, etc. on the delivery documents. Make a copy of the marked delivery receipt.
- * If the damage is minor or partial, that you choose to accept, you can contact the distributor or YMGI to discuss the possible replacement of the damaged part.
- * If refusal of the shipment is needed due to severe freight damage, **DO NOT** sign the carrier's delivery receipt document indicating that you accept the products. Mark receipt "REFUSED DUE TO FREIGHT DAMAGE." Sign and date along with the delivery driver's signature and date.
- * Take pictures showing the damage, before the delivery driver leaves.
- * If you accept the delivery or fail to note damage on the driver's delivery receipt, the ability to claim freight damage is lost and YMGI will not replace the unit on this basis.
- * Contact the distributor or YMGI, report the damage by forwarding the marked delivery receipt copy and pictures.
- * Only after YMGI verifies with the carrier the necessary detailed notes of received freight damage, will the damaged products be eligible for replacement.
- * If the returned products are found not damaged, YMGI will treat it as a return and will charge you 25% of product value plus added shipping cost.

RETURN-YMGI GROUP POLICIES & RETURN GOODS AUTHORIZATION (RGA)

All sales are final. If the customer wishes to return a product, the following **Return Policies** apply.

A. Only those products (units, parts or accessories) under the following conditions, are eligible for return:

1) Products are returned within 30 days of their original shipment date from YMGI

- 2) Products have not been installed.
- 3) No damage exists on the products being returned.
- 4) No missing products.
- 5) Products and packages are clean.
- 6) No duct tape or marking on the product or box.
- 7) Products are still their original package, in good shape and in re-sellable condition, as YMGI determines.

B. Preapproval steps for your return request:

- 1) Contact your distributor or YMGI to request a return.
- 2) Photograph your product and box to show details
- 3) YMGI will review your request, along with the pictures and any other details pertaining to your request.
- 4) If YMGI agrees to process your return request, a form called **Return Goods Authorization (RGA)**, along with **an assigned RGA #** will be forwarded to your distributor or you.
- 5) Any return without YMGI Group approved RGA #, will not be accepted.



CUSTOMER AND TECHNICIAN MUST READ

C. YMGI must verify the following before you can pack your products:

- 1) No products (units, parts, accessories) are missing.
- 2) No damage is found.
- 3) The products are in the original packaging.
- 4) No duct tape on any product or box.
- 5) Pictures have been taken and sent to YMGI to verify the product and boxes are not damaged.
- 6) The RGA has been completed and a copy has been returned to YMGI, via email or fax.
- 7) YMGI has approved the request in writing.

D. Shipping Preparation:

- 1) Package all products in a manner in which no damage can occur to the product and secure to a pallet.
- 2) Take and forward pictures of packed pallets for YMGI to verify proper packaging and no existing damage.
- 3) Include the YMGI approved RGA# in the shipping documents.
- 4) YMGI reserves the right to approve or deny any shipments.
- 5) YMGI can arrange shipping for you, but not at YMGI's cost. If this option is chosen, a packing list and BOL will be issued to you through YMGI.
- 6) If the above option is not chosen, you will be responsible for all freight charges. YMGI will not accept any returned items COD.
- 7) Place the package in an area which is accessible to the shipping company for pickup and limits the possibility of damage to the product. Customer must be present at the time of freight pick up.

After shipping, fax the BOL to YMGI Group at 1-866-377-3355 or email to customerservice@ymgigroup.com, detailing the information of the freight company and their tracking number.

E. Freight Damage:

- 1) YMGI Group will inspect returned items
- 2) Claiming of freight damage from a customer hired carrier will be the customer's responsibility.
- 3) Claiming of freight damage from a YMGI hired carrier will be YMGI's responsibility.

F. Charges for your return:

- 1) A restocking charge of 25% creditable invoice value.
- 2) All return shipping fees.
- 3) Additional fees will be charged, if products are found to be damaged, missing or used.
- 4) YMGI will notify the distributor of the charges only after the inspection and assessment of the returned products has been completed.

Attention:

- 1) Returned products must be shipped within 7 days of YMGI's releasing of **RGA #**.
- 2) **All RGA** shipping shall be prepaid by the customer. **YMGI will not accept any COD freight.**

YMGI GROUP DISCLAIMING-1:

YMGI Group will NOT accept any return, or may not honor 100% credit for any return of Product(s)/Part(s)/Accessories, in any of the following cases:

- * Return requests made 30 or more days after the date of original sales shipping from YMGI Group warehouse.
- * Return shipment is initiated 8 days or more after the RGA is approved.
- * Returned products received not displaying an YMGI-approved valid **RGA #**.
- * Returned products received C.O.D.
- * Returned products not received in the original packaging.
- * Returned products received with non-repairable packaging, including duct tape or marks on units or carton boxes.
- * Returned products received with missing units/parts/accessories.
- * Returned products received, are found to be non-functional or damaged.

YMGI GROUP DISCLAIMING-2:

- * YMGI Group will not be responsible for any losses of returned unit(s)/part(s)/accessories in transition to YMGI Group warehouse.
- * YMGI Group RGA is valid for seven (7) days from the original issuing date. Returns will not be accepted, if shipping is made 8 or more days after the YMGI Group RGA is issued.

CUSTOMER AND TECHNICIAN MUST READ

DEFECTIVE UNITS / PARTS / ACCESSORIES-REPAIR OR REPLACEMENT

Out of thousands of units sold every year, there may be an occasional instance your product does not operate properly. Reasons of but are not limited to: **manufacturing, installation, operation, maintenance and knowledge of operator.**

Equipment failure does not automatically denote a product defect from the factory assembly line. The defects can be caused, during production, transportation, installation, operation, maintenance, or service. Defects may NOT be the responsibility of the manufacturer. Nobody willfully or intentionally produces a defective product. No determination shall be made until the technical issue(s) or the causes of the defect(s) are identified.

The defects might be found before/ during installation or in the operation of the unit. Defects can be in the form of blown fuse(s), defective control board(s), damaged remote control, loose or missing screws, etc. These defective parts can be replaced easily.

Some functions of our units are different from what are typical in traditional split type air conditioning and heat pump systems and similar systems made by other manufacturers. These are not defects. Take some time to learn the functions of your unit. We will be happy to assist you with any questions you may have concerning the functions of your new unit.

If a defect is found, whether at the original installation, or during normal operation, we will gladly help you in the following steps in sequence from 1 to 3:

1. **Part repair or replacement after trouble-shooting:** This is the most common and generally the easiest and most economical way for all the needed parts since the problem and all part needs can be accurately and completely identified.

* Your technician calls our technical support line, from your job site, after checking your units and getting all the information ready.

* Our technical support will go through several steps, over the phone or through email, with your technician, in order to help identify and resolve the problems. Normally wiring correction, piping correction, part repair/ replacement will resolve the problems.

* Your technician will then need to verify and confirm the problem(s) before YMGI can ship out the replacement part(s). Inaccurate or incomplete troubleshooting or part replacement will delay the repair. YMGI technical support will only speak with a licensed/certified technician in regards to the repair of your unit. In our experience this saves time and money for all parties involved.

Your technician is the only person to perform any physical checking, trouble-shooting and replacing of any defective part(s) for your units. Our factory technical support is just a help. **YMGI provides no labor warranty on the products.**

2. **Unit/part repair at our workshop(s):** Due to the limitations of our technical support not being at your job site, or your technician's limited experience with our product, the problem may not be resolved as quickly as would be desired. If the problem is still not resolved after attempts between your technician and our technical support, you can elect to have the unit repaired at our facility. If this step is chosen:

- 1) YMGI will send to you the **Customer Request to Ship Products to YMGI Service Center for Inspection and Repair, and Authorization to Charge** form.

- 2) You will review the form and fill all fields appropriately, sign and send back to the YMGI Group.

- 3) Once the form has been completed and sent back to YMGI, remove the units and ship back to YMGI.

Please make a note describing the problem and communication history, if possible. Our technicians will check the units and find the problem(s), repair the issue(s), and ship the unit back to you following the conditions set forth in the signed repair agreement. All unit removal and re-installation is done at your cost and must be done by a currently valid licensed HVAC technician.

3. **Unit replacement:** Only applies to those defects reported within 30 days of original purchase date and if all necessary warranty paperwork had been received and approved. This option applies only if the above steps cannot resolve the problem(s). Either indoor or outdoor unit replacement is available, based on the actual need, at YMGI's determination. ***This option shall be the last resort***, due to refrigerant and wiring considerations. All unit removal, re-installation and shipping cost are the responsibility of the customer. YMGI maintains the final authority as to unit replacement. Replacement will be made with the same model only. Alternate units will be treated as a new order.

Returning Replaced Defective Units/Parts/Accessories After Unit Repair: (Only applies to steps 1&3 above)

- 1) Repack the replaced unit/ part /accessory in the box which contained the replacement part.

- 2) Parts can be boxed for UPS, FedEx or equivalent ground service. Units shall be secured onto the skid on which the replacement was shipped after placing into the package from the replacement product.

- 3) Ship **all** replaced products, to YMGI-designated location. You will be charged if YMGI does not receive the replaced parts.



CUSTOMER AND TECHNICIAN MUST READ

Standard factory warranty does not cover the cost of materials and labor that are incurred at your site. There will be no cost for the replacement unit, if YMGI determines the defect is manufacturer related. Replacement will be made with the same model, only. Alternate units will be treated as a new order.

CUSTOMER SERVICE / TECHNICAL SUPPORT FROM YMGI GROUP

For questions or help with your unit, contact the original installer or service provider.

YMGI Group does not install nor physically service your unit. Your installer or service provider must check the unit prior to contacting YMGI Group from your jobsite, in order to be helped in an efficient and timely manner.

* Factory customer service at customerservice@ymgigroup.com Tel: 1-866-833-3138x704

* Factory technical support at techsp@ymgigroup.com Tel: 866-833-3138x703

* Fax: 1-866-377-3355

An "**YMGI Group Customer Service/Technical Support Daily Log Sheet**" will be filed in writing at our office, for effective communication between you and YMGI Group customer service, your technician and YMGI Group technical support. Before contacting the YMGI Group locate the IP# written at the top of your warranty registration form. Use this IP# whenever you contact the YMGI Group.

DISTRIBUTOR AND MANUFACTURER POLICIES

* All questions concerning sales or money will be directed to the sales distributor from which you purchased the units.

* Read and follow all policies set forth from the distributor from which you purchased your unit.

* Upon purchase and installation of the unit(s), you agree to be bounded by all policies published by both distributors and YMGI.

* YMGI Group has the final authority and supersedes other related parties (distributors, etc.) concerning all policies regarding YMGI products.

YMGI DISCLAIMING-3 (RE: LIMITED PRODUCT WARRANTY)

- 1) The YMGI **Limited Product Warranty Policy**, details the eligibilities, coverage's and other explanations of the warranty terms between YMGI group and the unit owner.
- 2) The YMGI **Limited Product Warranty Policy** and the **Warranty Registration Card/Form** are either included inside the user's manual and/or installation instruction manual, or come separately in the unit packaging box/ envelope. If for any reason they are not included with your shipment, contact our sales or customer service to request a copy (electronic or printed), prior to installation.
- 3) The checklist, in the **Warranty Registration Card/Form**, is for the currently licensed/ certified HVAC technician to fill out completely, while verifying all unit functions are operating correctly. This checklist is for the technician to test and check all details of your unit, to verify and ensure its proper operation.
- 4) The technician must complete all fields in the **Warranty Registration Card/Form**, especially the unit model and serial numbers and distributor information, and most importantly, the technician checklist.
- 5) **Warranty Registration Card/Form** shall be mailed, **along with the original copy of the currently licensed HVAC contractor's full installation invoice**, to YMGI Group, within 7-days after original installation, in order for YMGI to review and process your warranty registration.
- 6) Keep a copy of **Warranty Registration Card/Form** for your own use in the future, to aid in any possible future warranty claiming, any request of parts, customer service, and/or technical support.
- 7) YMGI reserves the right to approve or deny the warranty status based on the information reviewed.

Mailing address of the **Warranty Registration Card/Form**: Warranty Department, YMGI Group, POB 1559, O'Fallon, MO 63366, USA.

USER NOTES AND INSTALLATION/SERVICE/MAINTENANCE NOTES

USER NOTES

Put down whatever questions you have or problems you have seen as a unit history:

No.	Date	Notes	Asked for Your Technician for Help?	Did You Ask YMGI Tech. for Help?

INSTALLATION NOTES

Put down whatever questions you have or problems you have seen as a unit history:

No.	Date	Original Installation Company Name, Technician Name, Phone & HVAC License #	Job Not Performed by Technician	Technician Checklist Completed Fully?

SERVICE / MAINTENANCE NOTES

No.	Date	Contents of Service / Maintenance	Technician's Company Name, Technician Name, Phone & HVAC License #



